

# **BV100 OPERATIONS MANUAL**

**INTELLIGENCE IN VALIDATION**

Innovative Technology assume no responsibility for errors, omissions, or damages resulting from the use of information contained within this manual.

## Contents

1 INTRODUCTION .....	2
2 ENVIRONMENT AND POWER REQUIREMENTS .....	4
3 GENERAL DESCRIPTION .....	5
4 MACHINE INTERFACES .....	7
4.1 BEZEL LED's .....	7
4.2 HARDWARE .....	7
4.2.1 PORTS AND BUTTONS .....	7
4.2.2 INTERFACE CONNECTOR PIN DETAILS .....	8
4.2.3 CONFIGURATION BUTTON FUNCTIONS .....	9
4.3 PROTOCOLS .....	10
4.3.1 SMILEY® SECURE PROTOCOL – SSP .....	10
4.3.2 CCTALK® PROTOCOL – CCT .....	11
4.3.3 MULTI-DROP BUS/INTERNAL COMMUNICATIONS PROTOCOL (MDB/ ICP) .....	11
4.3.4 SERIAL INPUT/ OUTPUT – SIO .....	12
4.3.5 PARALLEL INPUT AND OUTPUT .....	15
4.3.6 PULSE STREAM OUTPUT .....	15
4.3.7 BINARY OUTPUT – BIN .....	16
4.3.8 OTHER INTERFACES AVAILABLE UPON REQUEST BY ITL .....	17
4.4 USING BV100 CONFIGURATION CARDS .....	17
5 LOW POWER OPTION .....	18
6 RE-CALIBRATION .....	20
7 DIAGNOSTICS .....	21
8 SUPPORT .....	22
9 APPENDIX .....	23
9.1 APPENDIX A – HOW TO ORDER A BV100 VALIDATOR .....	23
9.2 APPENDIX B – BV100 MECHANICAL INSTALLATION .....	24
9.3 APPENDIX C – BV100 CASH BOXES .....	25
9.4 APPENDIX D – CONFIGURATION CARDS .....	26
9.5 APPENDIX E – ESCROW CONTROL .....	33
9.6 APPENDIX F – INTERFACE TOOLS DA1-DA2 .....	34
9.7 APPENDIX G – EXPLODED DIAGRAMS .....	36
10 INDEX .....	44

## 1 INTRODUCTION

### BV100 VALIDATOR - THE NEXT GENERATION OF ITL BANK NOTE VALIDATORS

This manual describes the operation of the BV100 Bank Note Validator as fitted with Firmware Version 4.00 or greater.

This document is intended for those who will:

- Install the BV100 equipment.
- Maintain the BV100 equipment.

Although information is included which will allow a degree of fault diagnosis and repair, it is recommended that for all but simple mechanical repairs, the unit must be returned to an approved service centre for repair.

For more concise information, addressed primarily to maintenance, please refer for the concise manual in our website.

### CAUTIONS

- This product must be fitted with a 3 A (ampere) fuse before use.
- The BV100 validator is pin for pin compatible with NV7/8/9/10, but not pin for pin compatible with the NV2/3/4/4x or 5 series products.
- Due to different note cycle times there may be timing differences from the NV products.
- Never exceed the recommended environmental and electrical limits.
- Do not attempt to lubricate the mechanisms as this may affect the note transport.
- Do not polish the lens as this may alter the optical characteristics.
- If the BV100 validator is disassembled the unit must be re-calibrated and re-initialised, following re-assembly.

### WARNING

- Only suitably trained personnel should carry out any work on this equipment in accordance with all current local, national and international health and safety regulations.
- We recommend that you study this manual as there are many new features permitting new uses and more secure applications.
- If you do not understand any part of this manual please contact the factory, contact details are below, for assistance. In this way we may continue to improve our product.
- The BV100 Validator has been designed to minimise any performance variation over time.
- Much of this is achieved by careful Hardware and Software design.
- Innovative Technology Ltd has a policy of continual product improvement. As a result the products supplied may vary from the specification described here.

This manual can be printed in A4 or letter sizes, without losing the scale. This is especially important in the Appendix D – Configuration Cards.

## MAIN HEADQUARTERS

Innovative Technology Ltd  
Derker Street – Oldham – England - OL1 4EQ  
Tel: +44 161 626 9999 Fax: +44 161 620 2090  
E-mail: [support@innovative-technology.co.uk](mailto:support@innovative-technology.co.uk)  
Web site: [www.innovative-technology.co.uk](http://www.innovative-technology.co.uk)



### AUSTRALIA

[support@innovative-technology.com.au](mailto:support@innovative-technology.com.au)

### BRAZIL

[suporte@bellis-technology.com.br](mailto:suporte@bellis-technology.com.br)

### CHINA

[support@innovative-technology.co.uk](mailto:support@innovative-technology.co.uk)

### GERMANY

[supportDE@innovative-technology.eu](mailto:supportDE@innovative-technology.eu)

### ITALY

[supportIT@innovative-technology.eu](mailto:supportIT@innovative-technology.eu)

### SPAIN

[supportES@innovative-technology.eu](mailto:supportES@innovative-technology.eu)

### UNITED KINGDOM

[support@innovative-technology.co.uk](mailto:support@innovative-technology.co.uk)

### REST OF THE WORLD

[support@innovative-technology.co.uk](mailto:support@innovative-technology.co.uk)

## 2 ENVIRONMENT AND POWER REQUIREMENTS

### ENVIRONMENT

Environment	Minimum	Maximum
Temperature	+3°C	+50°C
Humidity	5%	95% Non-condensing

Table 1 – Environmental Requirements

#### CAUTION:

Depending upon the environment in which it is used the BV100 may at some time require re-calibration. Please refer to Chapter 6 for details of the re-calibration process.

### POWER REQUIREMENTS

Electrical Supply	Minimum	Maximum
Supply Voltage (V DC) Absolute Limits	+11.5V	+14.2V
MDB IF5 Version Supply Voltage	+18V	+48V DC or 34V AC
MDB Hardware version	+18V	+48V DC
Supply Ripple Voltage	0 V	0.25 V @ 100 Hz
<b>Supply Currents:</b>		
Sleep (Low Power Mode)		2mA
Standby		230mA
Validating		500mA
Peak Motor Stall		2000mA

Table 2 – Power Requirements

Interface Logic Levels	Logic Low	Logic High
Inputs	0 V to + 0.5 V	+3.7 V + 12 V
Outputs with 2K2Ω pull up	0.6 V	Pull up voltage of host interface
Maximum Current Sink	50mA per output	

Table 3 – Interface Logic Levels

#### CAUTION

- If the input voltage falls below 11.5 V the BV100 may not operate correctly (will reject notes). The front bezel lights will flash to indicate incorrect conditions.
- It is recommended that the power supply used can supply at least 2.5 amperes.

## 3 GENERAL DESCRIPTION

The BV100 Bank Note System is a compact note-validating machine (see Figure 1), suitable for most money machines. It will accept up to 16 different denominations of notes in the serial control mode.

The BV100 is designed for easy installation in most machines. To see the general dimensions of the BV100, refer to Appendix B - BV100 Mechanical Installation.



Figure 1 - The BV100 validator

### Currency

The BV100 Validator leaves the factory preset to at least one currency so that it is ready for immediate installation. If the currency data set needs to change this may be done using the PC based Validator Management Software. New currencies and applications are being tested all the time, please refer to our web site or contact the factory for information concerning specific currencies if they are not already included on our approved list.

### Cash Box

Various size cash boxes are available for the BV100. The standard cash box will hold approximately 300 notes. Cash box spacers can be added at the factory to increase the capacity. Each spacer will add an extra 250 note capacity with a maximum of 2 spacers. This gives a maximum capacity of approximately 800 notes. (See Appendix C - BV100 Cash Boxes for more details). Cash box capacity must be stated at the time of ordering. If no capacity is specified, the standard cashbox will be delivered. **Note:** Cash box spacers can only be added at our factory, and once fitted cannot be removed.

### Secure lock for the cash box

A lock can be fitted to the BV100 to secure the cash box in place (lock part number PA650) **Note:** A locking cam (MC229) must also be fitted.

### Bezel sizes

The BV100 validator is available with either a 66 mm or 72 mm Bezel. See drawing number GA700 in Appendix B - BV100 Mechanical Installation, for general dimensions.

### Interface

Interfacing the validator is very simple, with the choice of the following protocols:

SSP	CCTALK	MDB	SIO
PARALLEL	PULSE	BINARY	NIS

Table 4 - Available Interfaces / Protocols

For detailed information about the different interfaces see Chapter 4.3.

## Hardware Options

In addition to the standard BV100, there are different hardware options of the BV100 available as follows:

### • **BV100 – MDB**

The BV100 MDB contains additional hardware for use in Vending machines operating at higher DC levels. The module provides a regulated 12 V DC supply to the validator and has Opto isolated inputs and outputs. For further details on the MDB protocol please see Chapter 4.3.3.

### • **BV100 – 110 V**

The BV100 110 V contains voltage regulator hardware that allows the BV100 to be used with machines that operate with a 110 V AC supply.

### • **Low power option**

The BV100 has a low power option to reduce the power consumption when idle. To learn more about the low power option, please refer to the Chapter 5.

## PC System Specification

The ITL Validator Software has been tested and verified using Windows 2000/XP/Vista™ on a Pentium™ based PC System (© Microsoft and Intel). Full functionality cannot be guaranteed on lower specification systems.

## 4 MACHINE INTERFACES

### 4.1 BEZEL LED's

The Bezel LED's are used to indicate a variety of status signals as described below.

Number of LONG flashes	Number of SHORT flashes			
	1	2	3	4
1	Note Path Open	Note Path Jam	Unit Not Initialized	
2	Cash Box removed	Cash Box Jam		
3	Firmware Checksum	Interface checksum	EEPROM Checksum	Dataset Checksum
4	PSU too Low	PSU too High		

Table 5 – Bezel LED status codes

### 4.2 HARDWARE

#### 4.2.1 PORTS AND BUTTONS

The BV100 interface connector is located on the left side of the unit; it has 16 pins (see Figure 2), refer to Table 6 for the pin allocation. Two are used for the 0V and +12V power supply and there are five outputs and five inputs, the remaining four pins are reserved for factory use and should not be connected. An example mating connector is Molex type Part No: 39-51-2160.

It is possible to use the special hardware versions of BV100 in machines operating at 110 volts or in machines operating at MDB.

The BV100 also has a Configuration Button located above the USB Connector (See Figure 2).

The USB connector can be used to program the BV100 and for communications when used in SSP and SIO modes. When used for programming, no external power supply is required.

When used for the communications, power must be applied to the BV100 via the 16 pin interface connector before connecting the USB cable.

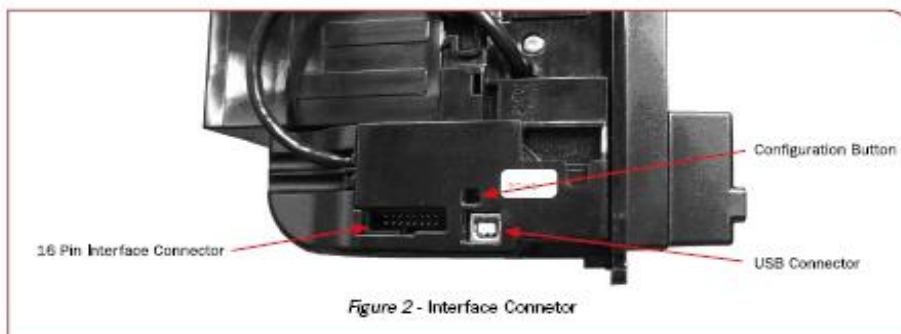





Figure 3 - Open head latch



Figure 4 - Cash box release button and cashbox access door

## 4.2.2 INTERFACE CONNECTOR PIN DETAILS

The connector pin details are described below (see table 5); they use an IDC 16-pin 0.1" pitch header with 2 rows of 8 pins.

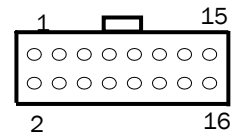

Figure 5 – Pin detail

Pin	Name	Description
1	Vend 1	Open collector outputs. Function changes depending on machine interface protocol (see individual interface descriptions for details.) Also the Pulse Steam output. Also the Serial Output pin in SSP Serial Mode and other serial modes.
2	Vend 2	Open collector outputs. Function changes depending on machine interface protocol (see individual interface descriptions for details).
3	Vend 3	
4	Vend 4	
5	Inhibit 1	Inhibit channel 1 by holding this pin HIGH. To Enable a channel the inhibit must be held LOW. Also the serial Input pin in SSP Serial Mode, and other serial modes.
6	Inhibit 2	Inhibit channel 2 by holding this pin HIGH
7	Inhibit 3	Inhibit channel 3 by holding this pin HIGH
8	Inhibit 4	Inhibit channel 4 by holding this pin HIGH
9	Busy	BV100 is validating and stacking output. Active low while the BV100 is reading, transporting or stacking a note
10	Escrow	Operate Escrow function by holding LOW (see Appendix B – Escrow Control for full details).
11	Factory use only	Do not connect
12	Factory use only	Do not connect
13	Factory use only	Do not connect
14	Factory use only	Do not connect
15	+Vin	Nominal 12V DC supply
16	0V	0V supply

Table 6 – 16 Pin Connector Details

## 4.2.3 CONFIGURATION BUTTON FUNCTIONS

The functions available via the Configuration Function Button are detailed in Table 7.

Configuration Button	Power Status	Function
Press and Hold (>2 secs)	Powered ON	Sets BV100 to Programming Mode (SSP)
Press Once (<1 sec)	Powered ON	Enables Configuration Card Programming
Press Twice (within half a second)	Powered ON	Current Setting Indicator
Press and hold as power is applied	Powered OFF/ON	Resets ccTalk key to Default setting

Table 7 – Configuration Button Functions

### BV100 Programming Mode

Press and Hold the Configuration Button for at least 2 seconds whilst the BV100 is powered up. The Bezel LED will flash rapidly to indicate that SSP is being loaded. Once this process has finished the BV100 will reset. The BV100 will now be in Programming Mode (SSP) and allow connection to a PC via a DA1 or DA2 adapter or connection to a DA3. **Note:** This mode can only be cancelled by re-programming with a Configuration Card or via the Validator Manager Program. Please ensure you are aware of all the BV100 programmed settings before entering this mode. Failure to restore the original setting will stop the BV100 from operating in the Host machine.

### Configuration Card Programming Mode

Press the Configuration Button once whilst the BV100 is powered up. If done correctly the Bezel LED will flash every 1 second. This will allow the insertion of a Configuration Card to change the Firmware Protocol in the BV100. (See chapter 4.4 Using BV100 Configuration Cards for full details). This mode can be cancelled by again pressing the Configuration button once.

### Current Setting Indicator Mode

Press the Configuration Button twice within half a second whilst the BV100 is powered up. The BV100 Bezel LED will then perform a series of flashes to indicate the current settings within the validator. (See Program Check Procedure, Appendix D - Configuration Cards)

### Encryption Key Reset Function (ccTalk®)

**Note:** This function will only be possible if the BV100 is programmed to ccTalk® mode. It is not possible to reset the key from SSP mode. Press and hold the Configuration Button whilst the BV100 power is off. Apply the power and keep the button pressed for several seconds. The ccTalk Encryption key will now be restored to the default setting.

## 4.3 PROTOCOLS

ITL strongly recommends the use of a Serial protocol (Preferably SSP) to achieve the highest security.

### 4.3.1 SMILEY® SECURE PROTOCOL – SSP

**NOTE:** Please refer to the Smiley® Secure Protocol (SSP) Specification (ITL Drawing GA138) on the website for full details of the SSP protocol. To use SSP mode, the SSP interface must be programmed into the validator via the Configuration Cards (See Appendix D - Configuration Cards) or via the ITL BNV Currency Manager Program, or by pressing and holding the Configuration Button for more than 2 seconds.

SSP is a secure serial interface specifically designed to address the problems experienced by cash handling systems in gaming machines. Problems such as acceptor swapping, reprogramming acceptors and line tapping are all addressed. This interface is recommended for all new designs.

The interface uses a master slave model; the host machine is the master and the peripherals (note acceptor, coin acceptor or coin hopper) are the slaves.

Data transfer is over a multi-drop bus using clock asynchronous serial transmission with simple open collector drivers. The integrity of data transfers is ensured through the use of 16 bit CRC checksums on all packets.

Each SSP device of a particular type has a unique serial number; this number is used to validate each device in the direction of credit transfer before transactions can take place.

Commands are currently provided for coin acceptors, note acceptors and coin hoppers. All current features of these devices are supported.

#### Features:

- Serial control of Note / Coin Validators and Hoppers.
- 4 wire (Tx, Rx, +V, GND) system.
- RS232 (TTL) - open collector driver.
- High Speed 9600 Baud Rate.
- 16 bit CRC error checking.
- Data Transfer Mode.

#### Benefits:

- Proven in the field.
- Simple and low cost interfacing of transaction peripherals.
- High security control of payout peripherals.
- Defence against surrogate validator fraud.
- Straight forward integration into host machines.
- Remote programming of transaction peripherals.
- Open standard for universal use.

For detailed information and full protocol specification please refer to SSP Interface Specification ITL (GA138), this is available from the ITL website [www.innovative-technology.co.uk](http://www.innovative-technology.co.uk).

To help in the software implementation of the SSP, ITL can provide DLL controls and Visual Basic applications on request. Please contact [support@innovative-technology.co.uk](mailto:support@innovative-technology.co.uk) for more information.

## 4.3.2 CCTALK® PROTOCOL – CCT

The BV100 supports the ccTalk serial protocol for easy interfacing with host machines that support this protocol. To use ccTalk® mode, the CCT interface must be programmed into the validator via the Configuration Cards (See Appendix D - Configuration Cards) or via the ITL BNV Currency Manager Program.

Pin out connections on BV100 for ccTalk are shown (see Figure 6) looking at the connection pins on the BV100 interface connector as defined in the ccTalk specification. It is recommended that all communications with the note validator must be encrypted using the encryption key, the default encryption key will be printed on the label of the BV100. To reset the Encryption key to its default value see Chapter 4.2.3. **NOTE:** For detailed information and full protocol specification please refer to [www.cctalk.org](http://www.cctalk.org).

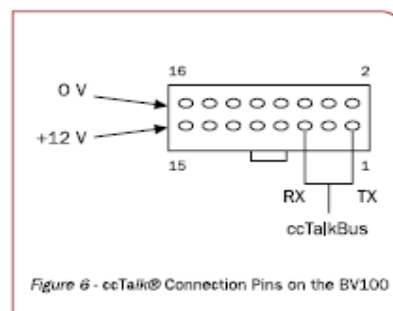

Figure 6 - ccTalk® Connection Pins on the BV100

## 4.3.3 MULTI-DROP BUS/INTERNAL COMMUNICATIONS PROTOCOL (MDB/ ICP)

To use the MDB mode an MDB BV100 or an IF5 interface box can be used. The MDB interface must be programmed into the validator via the Configuration Cards (See Appendix D - Configuration Cards) or via the ITL BNV Currency Manager program.

### Note:

- An IF5 cannot be used with an MDB BV100.
  - A standard BV100 can only be used in MDB with the addition of an IF5 interface.
  - Please refer to the Multi-Drop Bus specification for the suggested current drive circuits available.
  - The BV100 supports the MDB protocol version 1, level 1.
  - For detailed information and full protocol specification please refer to [www.vending.org](http://www.vending.org)
- MDB defines a serial bus interface used in electrically controlled vending machines (see Figure 7).

This is a 9600 Baud Master-Slave system where the BV100 Banknote Validator is a slave to a master controller. A master has the capability of communicating with 32 peripherals or slaves. The master is defined as the Vending Machine Controller (VMC). The BV100 banknote Validators have a unique address – 00110XXX binary (30H). The VMC polls the bus to detect presence of the BV100 Validator or get information on the current status of the validator.

The validators will respond when asked for activity with an acknowledgment, a negative acknowledgment or a specific reply, depending on its current status. Bus crashes are avoided as the Validators respond to being polled only by the VMC.

The international country code must be set for the country in which the Validators will be operating. This is either the international telephone code for that country, or the country code taken from ISO4217. The code is represented as two bytes. The initial digit signifies the source of the code. 0 signifies the telephone code is used, 1 signifies ISO4217 has been used.

For the USA the country code is 00 01, or 18 40

For Great Britain the code is 00 44, or 18 26.

The scaling factor must also be specified for each Validator. All accepted note values must be evenly divisible by this number.

- This number would be set to 100 (Hex 64) for the Euro or Great Britain.
- The number would be set to 1000 (Hex 03E8) for Colombia.

The number of decimal places must also be programmed for each Validator

- The number would be set to 2 for Euro or USA
- The number would be set to 3 for Colombia

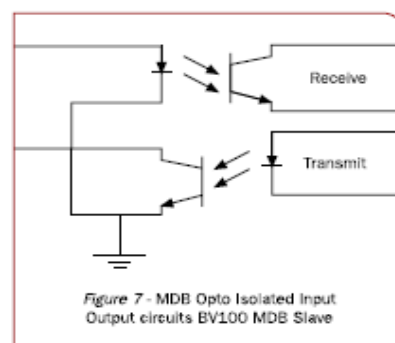

Figure 7 - MDB Opto Isolated Input Output circuits BV100 MDB Slave

Adopting the numbers above.

- £5 would be displayed as 5.00
- £10 would be displayed as 10.00
- \$1 would be displayed as 1.00
- 1K Colombia would be displayed as 1.000

#### 4.3.4 SERIAL INPUT/ OUTPUT - SIO

Existing Smiley® NV4 - NV10 users may already be using the serial input/output facility in conjunction with the parallel inputs. The BV100 Validator also supports this system.

However this interface is not recommended for new designs, the Smiley® Secure Protocol SSP interface is recommended.

#### CAUTION

- The BV100 does not support the simple serial data out only mode as available on NV4 and earlier models NV2 and NV3. It only supports the serial data input/output mode.
- The host machine does not echo messages back to the validator.
- The BV100 does not operate in true RS232 mode. (Only TTL level).

To use Serial Input/Output mode, the SIO interface must be programmed into the validator via the Configuration Cards (See Appendix D - Configuration Cards) or via the ITL BNV Currency Manager Program.

#### There are 4 different combinations of SIO available:

SIO 300 Baud

SIO 300 Baud (Disabled at Start up) - A software enable must be sent to enable the validator.

SIO 9600 Baud

SIO 9600 Baud (Disabled at Start up) - A software enable must be sent to enable the validator.

#### The data is formatted as follows for 300 Baud:

1 start bit - 8 data bits - 2 stop bits

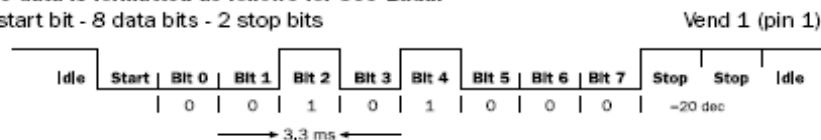

Figure 8 - Typical Serial Output: Transmission of the value 20 (decimal), note not recognized

#### The data is formatted as follows for 9600 Baud:

1 start bit - 8 data bits - 1 stop bits



Figure 9 - Typical Serial Output: Transmission of the value 20 (decimal), note not recognized

The BV100 will receive and transmit the following event codes:

Recognised Receive Codes to BV100		Transmitted codes from BV100	
MESSAGE	DECIMAL VALUE	MESSAGE	DECIMAL VALUE
Inhibit C1	131	Note Accept on C1	1
Inhibit C2	132	Note Accept on C2	2
Inhibit C3	133	Note Accept on C3	3
Inhibit C4	134	Note Accept on C4	4
Inhibit C5	135	Note Accept on C5	5
Inhibit C6	136	Note Accept on C6	6
Inhibit C7	137	Note Accept on C7	7
Inhibit C8	138	Note Accept on C8	8
Inhibit C9	139	Note Accept on C9	9
Inhibit C10	140	Note Accept on C10	10
Inhibit C11	141	Note Accept on C11	11
Inhibit C12	142	Note Accept on C12	12
Inhibit C13	143	Note Accept on C13	13
Inhibit C14	144	Note Accept on C14	14
Inhibit C15	145	Note Accept on C15	15
Inhibit C16	146	Note Accept on C16	16
Un-inhibit C1	151	Note Not Recognised	20
Un-inhibit C2	152	Mechanism running slow	30
Un-inhibit C3	153	Strimming attempted	40
Un-inhibit C4	154	Channel 5 Note Rejected (fraud channel)	50
Un-inhibit C5	155	STACKER Full or Jammed	60
Un-inhibit C6	156	Abort During Escrow	70
Un-inhibit C7	157	Note may have been taken to clear jam	80
Un-inhibit C8	158	Validator Busy	120
Un-inhibit C9	159	Validator Not Busy	121
Un-inhibit C10	160	Command Error	255
Un-inhibit C11	161		
Un-inhibit C12	162		
Un-inhibit C13	163		
Un-inhibit C14	164		
Un-inhibit C15	165		
Un-inhibit C16	166		
Enable serial escrow mode	170		
Disable serial escrow mode	171		
Accept escrow	172		
Reject escrow	173		
Status	182		
Enable all	184		
Disable all	185		
Disable escrow timeout	190		
Enable escrow timeout	191		
Request firmware	192		
Request dataset	193		

Example transactions are shown below:

Table 9- Example Protocols

Event	Validator	Decimal Value	Host
Note entered into validator	Validator Busy	120→	
Note accepted channel 2	Validator Ready	121→	
	Accept on channel 2	2→	
Note entered into validator	Validator Busy	120→	
Note not recognised	Validator Ready	121→	
	Note not recognised	20→	
Validator has returned note	Validator Ready	121→	
Software Inhibit Channel 4	Inhibit C4	←134	Inhibit C4
	Channel 4 inhibited	134→	
Software Enable Channel 4	Uninhibit C4	←154	Uninhibit C4
	Channel 4 inhibited	154→	
Status Report		←182	Status Request
	Status Requested	182→	
3 byte status message	Inhibit status Channels 1-8	Byte 1→	
	Inhibit status Channels 9-16	Byte 2→	
	Escrow On (=1) / Off (=0)	Byte 3→	
Turn on Escrow Mode		← 170	Enable Escrow Mode
	Escrow Mode Enabled	170→	
Note accept in Escrow Mode			
Note entered into validator	Validator Busy	120→	
Note Accepted Channel 2	Validator Ready	121→	
	Accept on Channel 2	2→	
		←172	Accept Note in Escrow
	Accept Escrow	172→	
	Accept on Channel 2	2→	
Event	Validator	Decimal Value	Host
Note entered into validator	Validator Busy	120→	
Note accepted channel 2	Validator Ready	121→	
	Accept on channel 2	2→	
Note entered into validator	Validator Busy	120→	
Note not recognised	Validator Ready	121→	
	Note not recognised	20→	
Validator has returned note	Validator Ready	121→	
Software Inhibit Channel 4	Inhibit C4	←134	Inhibit C4
	Channel 4 inhibited	134→	
Software Enable Channel 4	Uninhibit C4	←154	Uninhibit C4
	Channel 4 inhibited	154→	
Status Report		←182	Status Request
	Status Requested	182→	
3 byte status message	Inhibit status Channels 1-8	Byte 1→	
	Inhibit status Channels 9-16	Byte 2→	
	Escrow On (=1) / Off (=0)	Byte 3→	
Turn on Escrow Mode		← 170	Enable Escrow Mode
	Escrow Mode Enabled	170→	
Note accept in Escrow Mode			
Note entered into validator	Validator Busy	120→	
Note Accepted Channel 2	Validator Ready	121→	
	Accept on Channel 2	2→	
		←172	Accept Note in Escrow
	Accept Escrow	172→	
	Accept on Channel 2	2→	



## 4.3.5 PARALLEL INPUT AND OUTPUT

To use Parallel Output for 4-note/channel acceptance the Parallel interface must be programmed into the validator via the Configuration Cards (See Appendix D – Configuration Cards) or via the ITL BNV Currency Manager Program.

**Vend Signals:** (Pins 1 to 4). The four channels have their own individual outputs. If a note is recognised then the relevant Vend line is set low for a period of  $100 \pm 3$  ms. Pulses outside these limits should be rejected as a precaution against false triggering.

**Busy Output:** (Pin 9). This is a general-purpose busy signal. It is active low while the BV100 is in operation.

**Escrow Control:** (Pin 10) Hold this pin Low to enable the single note escrow function. (See Appendix E – Escrow Control). If the host machine aborts the transaction by setting the corresponding inhibit input high, the note is returned immediately.

The host machine can force the return of the note to the customer by setting the inhibit line high, at any time before the end of the 30 second time-out. Setting all the inhibits high causes a note reject.

In the event of a note being forcibly removed from the mouth of the BV100 during the 30- second interval, the BV100 will go out of service for 45 seconds.

**Inhibit Operation:** (Pins 5 – 8) Channels 1 to 4 have their own inhibit input to allow the host machine to refuse specified notes. To inhibit a channel, the relevant inhibit input must be held high. To enable a channel, the corresponding inhibit must be latched low so that notes may be accepted.

If all four inhibits are high simultaneously then the BV100 will be disabled. In this state the bezel LED will not illuminate and if a note is inserted the motor will run in reverse preventing the insertion of the note.

All four inhibits may be connected together to create a 'global' inhibit. In this way the BV100 may be brought in and out of operation by the host machine.

It is possible to operate the BV100 in Low power mode with the Parallel interface. For further details please see Chapter 5.

## 4.3.6 PULSE STREAM OUTPUT

To use pulse stream output for acceptance of up to 16 note/channel acceptance, The Pulse interface must be programmed into the validator via the Configuration Cards (See Appendix D – Configuration Cards) or via the ITL BNV Currency Manager Program.

**Vend Signal:** (Pins 1) When a note is recognised vend 1 will pulse a pre-set number of times, the number of pulses can be set via the ITL BNV Currency Manager Program (and set to default values with supplied dataset). The pulse width can be set either with the ITL BNV Currency Manager Program or via the Configuration Cards (See Appendix D - Configuration Cards)

**Busy Output:** (Pin 9). This is a general-purpose busy signal. It is active low while the BV100 is in operation.

**Escrow Control:** (Pin 10). No escrow function in this mode

**Inhibit Operation:** (Pins 5 – 8) Channels 1 to 4 have their own inhibit input to allow the host machine to refuse specified values of notes. To inhibit a channel, the relevant inhibit input must be held high. To enable a channel, the corresponding inhibit must be latched low so that notes may be accepted.

If all four inhibits are high simultaneously then the BV100 will be disabled. In this state The bezel will not illuminate and if a note is inserted the motor will run in reverse preventing the insertion of the note.



**Note:** Channels higher than four cannot be individually inhibited, but will be globally inhibited if inhibits 1 to 4 are inhibited.

It is possible to operate the BV100 in Low power mode with the Pulse interface. For further details please see Chapter 5.

### **Credit Hold Function:**

If this function is enabled in pulse mode by Configuration card or ITL BNV Currency Manager Program, the validator will take the note as normal but then wait until the escrow line is toggled low/high before. It will then give out the number of pulses per dollar as set on the programming card. After the pulses have been given, the validator will then wait for another low/high toggle until the full value of credit pulses are given.

For example with a setting of 2 pulses per dollar, a five dollar bill will give 2 pulses, 5 times.

A Typical use of this option would be for a Pool table with a game price of \$1. You could insert a \$5 note and press a button that toggles the escrow line and releases the pool balls, this would then allow you to play the first game. The Validator holds onto the remaining credits until the game has finished and the button is pressed again allowing the next game to begin, this continues until all the credits have been used.

The busy line remains low throughout the whole process and the validator remains inhibited until all pulses are given.

### **4.3.7 BINARY OUTPUT – BIN**

To use Binary mode the Binary interface must be programmed into the validator via the Configuration Cards (See Appendix D – Configuration Cards) or via the ITL BNV Currency Manager Program.

In the event that the machine needs more than 4 notes to be recognised, but the host machine cannot take advantage of the serial communication methods then the BV100 can be set to give a binary pattern output on the four parallel output pins. If the BV100 is set to binary mode it will issue the vend signals as a binary pattern on the parallel outputs for  $100 \pm 3$  ms. In this way a maximum of 15 different notes can be accepted and 4 notes individually inhibited.

**Vend Signals:** (Pins 1 to 4). The four channels have their own individual outputs. If a note is recognised the binary representation of the channel number will be pulled low for  $100 \pm 3$  ms. Pulses outside these limits will be rejected as a precaution against false triggering due to noise.

**Busy Output:** (Pin 9). This is a general-purpose busy signal. It is active low while the BV100 is in operation.

**Escrow Control:** (pin 10). Hold this pin Low to enable the single note escrow function. (See Appendix E – ESCROW Control).

If the host machine aborts the transaction by setting the corresponding inhibit input high on pin 10, the note is returned immediately.

The host machine can force the return of the note to the customer by setting the inhibit line high, at any time before the end of the 30 second time-out. Setting all the inhibits high causes a note reject.

In the event of a note being forcibly removed from the mouth of the BV100 during the 30-second interval, the BV100 will go out of service for 45 seconds.

**Inhibit Operation:** (Pins 5 – 8) Channels 1 to 4 have their own individual inhibit input to allow the host machine to refuse specified values of notes. To inhibit a channel, the relevant inhibit input must be held high. To enable a channel the corresponding inhibit must be latched low so that notes may be accepted. If all four inhibits are high simultaneously then the BV100 will be disabled. In this state the bezel will not illuminate and if a note is inserted the motor will run in reverse preventing the insertion of the note.

**Note:** Channels higher than four cannot be individually inhibited, but will be globally inhibited if inhibits 1 to 4 are inhibited. It is possible to operate the BV100 in Low power mode with the Binary interface. For further details please see the next chapter.

## 4.3.8 OTHER INTERFACES AVAILABLE UPON REQUEST BY ITL

Any queries regarding interfaces not mentioned in this manual should be made to [support@innovative-technology.co.uk](mailto:support@innovative-technology.co.uk)

## 4.4 USING BV100 CONFIGURATION CARDS

The Configuration Cards offer the following functions:

- Select required Communication Interface (SSP, ccTalk, Parallel etc).
- Adjust the channel and pulse configuration on a pre-programmed BV100 to your own requirements.

Programming the BV100 with the configuration cards is enabled via the 'Configuration Button' on the right hand side of the BV100 (see Chapter 4.2.3). (For details on how to complete the configuration cards please see Appendix D – Configuration Cards).

### Instructions

- 1) Press the Configuration button once whilst the validator is powered up.
- 2) The bezel LEDs will now flash with a steady heartbeat until a Configuration Card is entered.
- 3) Once the Configuration Card has been entered the validator reads the card and immediately returns it.
- 4) The LEDs then flash rapidly whilst the interface is being changed. If the LEDs flash a number of times slowly, it is an indication of an error (For details of the Error Flash Codes please see Appendix D – Configuration Cards).
- 5) When the changes are complete the validator resets.

If a configuration card is not entered, this function can be cancelled by pressing the button again once.

It is now possible to check the programmed settings of the BV100 by pressing the configuration button twice within half a second. (For details see Appendix D – Configuration Cards).

## 5 LOW POWER OPTION

Low power Mode can be used with all non-serial communication protocols to reduce the power consumption of the BV100 when idle.

When the BV100 is in this state the current consumption is reduced. The BV100 goes into low power mode approximately 6 seconds after the validator is powered up and remains in this state until a note is entered (Time A, Figure 10). Following a note insertion the BV100 returns to Low Power mode approximately 1 second after the Busy line goes High (After credit is given or note is rejected), (Time B, Figure 10).

Electrical Supply	Minimum	Maximum
Supply Voltage (V DC) Absolute Limits	+11.5V	+14.2V
MDB IF5 Version Supply Voltage	+18V	+48V DC or 34V AC
MDB Hardware version	+18V	+48V DC
Supply Ripple Voltage	0 V	0.25 V @ 100 Hz
<b>Supply Currents:</b>		
Sleep (Low Power Mode)		2mA
Standby		230mA
Validating		500mA
Peak Motor Stall		2000mA

Table 10 - Electrical requirements and characteristics for low power mode

### Notes:

- Low Power Mode can ONLY be used with the above Parallel, Pulse and Binary protocols.
- Low power mode can only be enabled by correctly completing the configuration cards or via the ITL BNV Currency manager program.
- In Low Power Mode the front sensor is checked every 1 second which can lead to a delay in accepting the note when it is presented.
- Configuration button functions are only available during power up before the BV100 goes into Low Power Mode.

Low power mode uses 3 control lines Vend–Pin 1, Inhibit–Pin 6 and Busy–Pin 9.

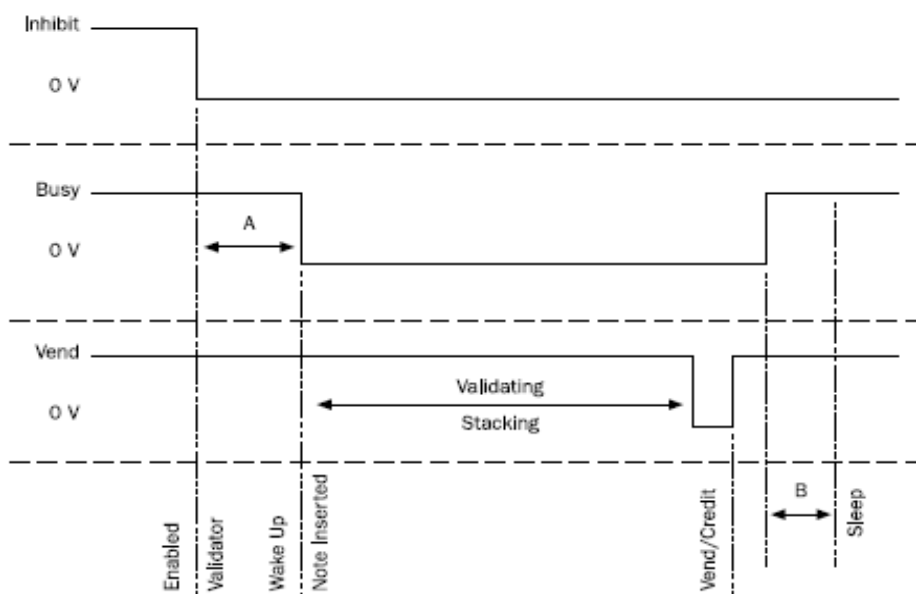

Figure 10 – Low power mode timing diagram

## TIMING DIAGRAM EXPLANATION

When the Validator is enabled the Inhibit line is Low and the Busy line is High. This remains the same until a note is inserted (Time A).

When a note is inserted under the front sensor the BV100 wakes up and the busy line goes low to indicate that the validator is in use. The busy line remains low during the validating and stacking process and once the note has been successfully validated and stacked the vend line goes low to issue the credit.

After the credit is issued the busy line goes high and approximately 1 second after the busy line goes high (Time B), the BV100 goes back into low power mode.

## 6 RE-CALIBRATION

The BV100 has an in-built self-calibration system that maintains the optical sensors at their best operating point.

However if the BV100 is disassembled for any reason it will need to be re-calibrated. Re-calibration may only be performed under license from ITL, contact [support@innovativetechnology.co.uk](mailto:support@innovativetechnology.co.uk) for further details.

This can be performed in conjunction with the diagnostics software option in the ITL BNV Currency Manager Program and help menus supplied with this program.

## 7 DIAGNOSTICS

<i>Symptom</i>	<i>Possible Cause</i>	<i>Corrective Action</i>
All notes are rejected (Bezel LED's are on)	Incorrect currency file programmed	Check that the required dataset is programmed into the validator using the validator manager software.
	Notes are not included in the currency file	Check that the required note denomination and issue is included in the currency file using the validator manager software.
	Notes are inhibited by the host machine	Ensure the machine is ready to accept notes. If a coin hopper is in the machine, ensure it is not empty. Ensure the maximum allowed credit on the host machine has not been exceeded.
	Bill path obstructed	Check for necessary clearance for note ejection after acceptance.
	Reader module is not fully inserted	Ensure the reader module is fully inserted into the main body of the validator.
Notes are not taken in (no bezel LED's)	No Power	Ensure the correct specification of power is applied to the validator.
	Incorrect interface is programmed	Check which interface is programmed into the validator by double clicking the configuration button. The displayed code indicates which interface is programmed as described in Appendix D – Configuration Cards)
	Reader module is not fully inserted	Ensure that the validator reader module is fully clipped in to the validator housing.
Notes stacked but no credit given	Incorrect interface is programmed	Check which interface is programmed into the validator by double clicking the configuration button. The displayed code indicates which interface is programmed as described in document number GA713.
	Power supply outside specification	Ensure correct supply and sufficient current. Also check for necessary clearance for note ejection after acceptance.
	Rear note detect sensor obscured	Remove the cash box and ensure no foreign objects are obstructing the sensors.
Acceptor runs slowly or intermittently	Foreign objects in the bill path	Clean the bill path
	Incorrect voltage level of supply	Ensure correct supply and sufficient current
	Damage in the unit	Replace necessary components
Bezel LED's are flashing	See chapter 4.1 for details of LED status signals	
Motor continues to run	Foreign object or note is stuck in the note path	Ensure the note path is clear and reset the validator. It may also be necessary to reset the host machine.

## 8 SUPPORT

The following support tools are available for use with the BV100 Bank Note Validator:

- Configuration Cards.
- ITL Bank Note Validator Currency Manager Software.
- Validator Programming System (DA3)
- Downloads from the Innovative Technology Ltd website: [www.innovative-technology.co.uk](http://www.innovative-technology.co.uk)
- E-mail Support via [support@innovative-technology.co.uk](mailto:support@innovative-technology.co.uk)

### Configuration Cards

For full details of the use and function of the Configuration Cards please see Appendix D

- Configuration Cards.

ITL Bank Note Validator Currency Manager

### Notes:

- The Validator must be set to Programming Mode (SSP) when connected to a computer or DA3 and then returned to the original Settings when complete (See Chapter 4.2.3).
- ITL BNV Currency Manager 3.2.0 or Higher must be used to access the BV100 functions.
- Datasets can only be downloaded to a BV100 with the correct bezel width for the currency. For example a USD dataset can only be downloaded to a 66 mm BV100. A Euro dataset can only be downloaded to a 72 mm BV100.

### The ITL BNV Currency Manager software offers the following functions:

- Program the Validator by downloading pre-prepared currency data via the DA1 or DA2 kit.
- Check the firmware version and currency set already loaded on a BV100 unit.
- Adjust the channel and pulse configuration on a pre-programmed BV100 to your own requirements.
- Download a new version of firmware onto the BV100.
- Use diagnostic functions to check Validators operation.

The software will run on an IBM compatible Personal Computer with Pentium™ processor or equivalent (see the General Description chapter for operating system requirements).

The BV100 can be connected directly via the USB port, or with either a DA1 kit fitted to the serial port or DA2 kit fitted to the USB port. (See Appendix F – Interface Tools DA1 – DA2)

### Validator Programming System (DA3)

The DA3 is a programming system designed to enable the programming of ITL Bank Note Validators in the field without the use of a PC.

### Once the DA3 has been programmed the user can:

- Reprogram the validator to accept a different currency using the BNV Override Download function.
- Test the functionality of the validator away from the Host machine.

For full DA3 operation and functionality details please refer to the DA3 User Manual (Document number GA339)

**Note:** When using the DA3 BNV Match Download function, any pulses and channel allocations programmed into the BV100 will not be retained. The user must ensure that the required dataset options are set and saved before programming the DA3.

When programming a BV100 using the DA3 BNV Override Download function, the firmware interface will not be changed. If a different interface is required, the user must use a configuration card to select the required interface.

### Internet Website Support

The Innovative Technology Ltd website provides the means to download new and updated currency sets and new versions of firmware for the BV100. You can obtain these along with technical bulletins by visiting [www.innovative-technology.co.uk](http://www.innovative-technology.co.uk)

### E-mail Support

If the data you require is not available over the Internet, Innovative Technology supports an e-mail system to help customers with unusual requirements. The address is: [support@innovative-technology.co.uk](mailto:support@innovative-technology.co.uk).

## 9 APPENDIX

### 9.1 APPENDIX A – HOW TO ORDER A BV100 VALIDATOR

To order a validator, please print and fill the order form, below, and send it to our nearest office. You may send it by fax or email. To find our contact information, please go to our website or refer to the introduction chapter in this document. If you do not know which office to send the order form, just send it to our main headquarters:

<b>INNOVATIVE TECHNOLOGY LTD</b>	Derker Street – Oldham – England - OL1 4EQ Tel: +44 161 626 9999 Fax: +44 161 620 2090 E-mail: <a href="mailto:support@innovative-technology.co.uk" style="color: white;">support@innovative-technology.co.uk</a> Web site: <a href="http://www.innovative-technology.co.uk" style="color: white;">www.innovative-technology.co.uk</a>
----------------------------------	---

If you have any questions about the information required for the order form, please see chapter 3 General Description. If you still have any questions, or you want to know more about other products and possibilities, do not hesitate to contact your local trading partner. We offer a wide range of products and accessories such as alternative validators, programming kits, interfaces, connecting cables, bezels and other elements. Please contact your nearest office for more information (<http://www.innovative-technology.co.uk/contact/contact-itl>)

<b>BV100</b>	Date: <input style="width: 90%;" type="text"/>
--------------	--

#### Customer Details

Company	Phone Number:
Contact Person	Country:
Issue No.	Customer Part No:

	BV100		
Product			
Dataset			
Firmware Version			
Firmware Interface			
Cashbox Capacity			
ccTalk Encryption Key			

#### APPROVED

Customer:	Innovative Technology:
-----------	------------------------



## 9.2 APPENDIX B – BV100 MECHANICAL INSTALLATION

In line with continued product development Innovative Technology Ltd reserves the right to change specification without prior notice.

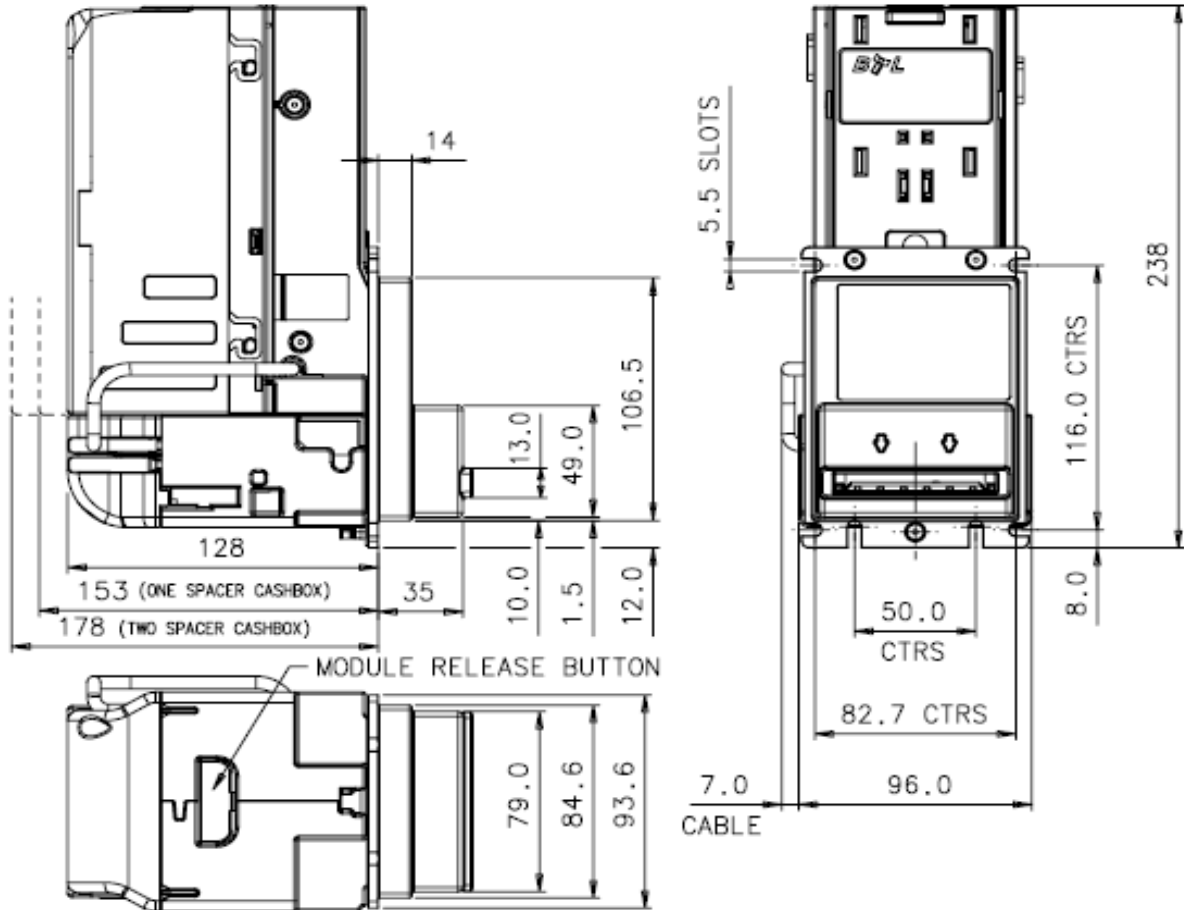

1. 66 mm x 160 mm LONG
2. 72 mm x 160 mm LONG
SUPPLY AND POWER CONSUMPTION:
VOLTAGE: 11 - 15V
RIPPLE: 0.25 V at 100 Hz
STAND BY: 270mA
VALIDATING: 770mA
PEAK: 2200mA
SLEEP: 1.6mA
<b>ENVIRONMENTAL OPERATING RANGE:</b>
+3 °C to +50 °C at 5% to 95% RH (NON - CONDENSING)
UNLADEN WEIGHT: 1 KG

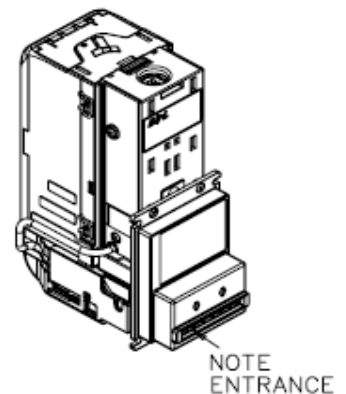

## 9.3 APPENDIX C – BV100 CASH BOXES

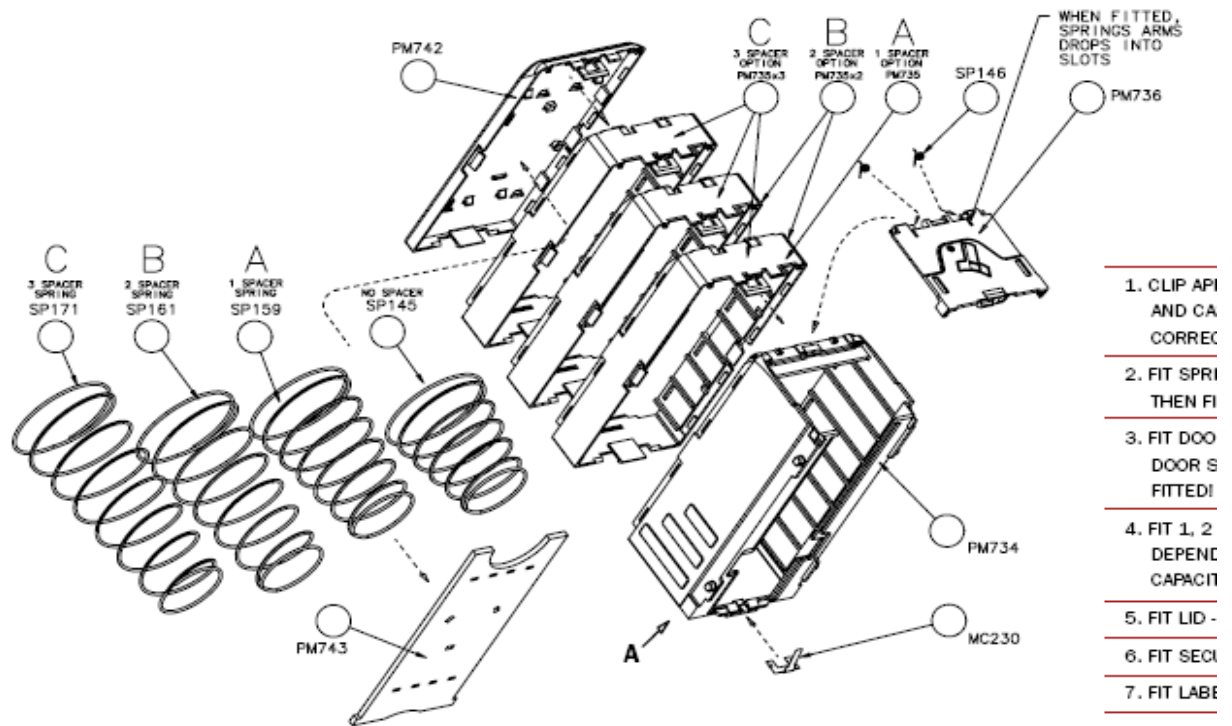

1. CLIP APPROPRIATE SPRING TO LID PM742 AND CASH PLATE PM743 (ENSURE CORRECT ORIENTATION)
2. FIT SPRING TO DOOR LATCH PM737, THEN FIT TO DOOR PM736
3. FIT DOOR SPRINGS THEN FIT DOOR - THE DOOR SHOULD SPRING SHUT WHEN FITTED!
4. FIT 1, 2 OR 3 SPACERS (PM735) DEPENDING ON REQUIRED NOTE CAPACITY
5. FIT LID - CASH PLATE
6. FIT SECURITY TOOTH MC230
7. FIT LABEL

**VIEW A**  
END OF CASHBOX  
POSITION OF WHITE LABEL



LABEL MUST COVER THE TWO HOLES  
LABEL TO FIT ON TOP OF RAISED SECTION,  
MUST NOT OVERHANG EDGES

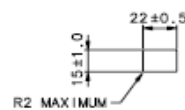

**LABEL MATERIAL:**  
SELF ADHESIVE GLOSS WHITE PLASTIC (NOT PAPER)  
IF THIS SIZE NOT AVAILABLE CUT TO SIZE FROM BIGGER LABELS

## 9.4 APPENDIX D – CONFIGURATION CARDS

The following pages contain the information corresponding to the document number GA713. To print the cards, ensure that the page scaling is set to 'none'. Always ensure that the card has printed with the correct dimensions before use.

### BV CONFIGURATION OPTION PROGRAMMING

Instructions for use

- 1) Select correct width card for bezel. Cut card around outline – check measurements as printed. Check print options 'Page scaling' is set to 'none' when printing a pdf file to ensure correct size.
- 2) Fill in sections as required. Take care to fill in the selections correctly, keep inside the lines and fill boxes fully as example below.



- 3) Power up BV100 and allow it to reset.
- 4) Click 'function' button on BV to access Configuration Mode, BV bezel LEDs should be flashing at 1 second intervals.
- 5) Enter card into BV in direction indicated by arrows.
- 6) Card will be returned and if configuration was good the bezel LEDs will flash rapidly while programming takes place. take care to ensure the power is not removed at this stage, the bv may suffer permanent damage!! The BV will then reset.
- 7) If an error occurs has occurred the card will be rejected and the bezel LEDs will flash slowly a number of times to indicate the cause of the error. (see table below)
- 8) important check that the configuration requested has been set in the BV100 before use.

Flash	Error
2	Invalid card read – card entered wrong way round, card mis-read or card wrong version
3	No interface selection was detected on card
4	Multiple interface selections detected
5	Invalid interface selected – the selected interface is not available for this BV
6	Selected interface not compatible with BV version
7	Pulse configuration error. Selected pulse options invalid.
8	ccTalk configuration error. Selected cctalk options invalid (ccTalk 8 bit chk not allowed without ccTalk Plain)
9	Low power mode not available on this BV version

Program check procedure

To check settings on a programmed unit:

Power on unit

Click program set button on unit twice (like double click on mouse)

Monitor bezel led and check flash codes

	Flash count	Pulse high	Pulse low	Pulse per dollar	High speed	Disabled	ccTalk plain	Low power	Binary	Credit hold
SSP	1									
Pulse	2	ms/10	ms/10	value						3 flash
MDB	3									
IF30	4									
IF31	5									
ccTalk	6						1 flash	2 flash		
SIO	7				1 flash	2 flash				
Parallel	8								1 flash	
spare	9									
NIS	10									
IF32	11				1 flash					
spare	12									
spare	13									
spare	14									

For example:

A pulse interface with 50ms high, 100ms low, 2 pulse per dollar will flash 2,5,10,2

A SSP interface will only ever flash once

A ccTalk interface with 16 bit checksum, no encryption will flash 6,1

A ccTalk interface with 8 bit checksum, no encryption will flash 6,1,2

A Binary interface will flash 8,1



## 72mm Bezel

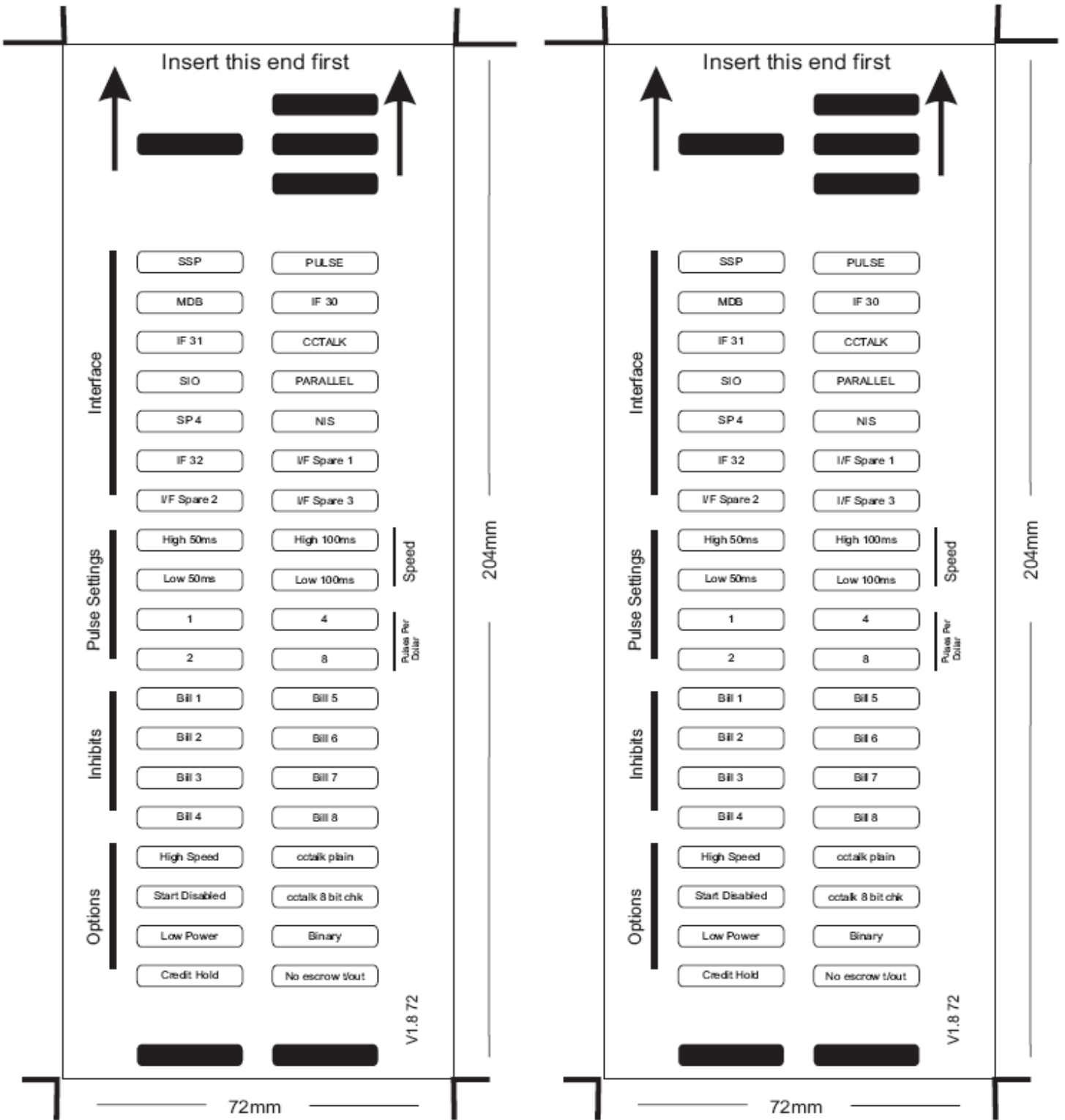

# BV100 Operations Manual

Below are some typical examples of completed Configuration Cards.

**Note:** These Configuration Cards are samples and should not be copied for programming use. Please see document GA713 for useable cards.

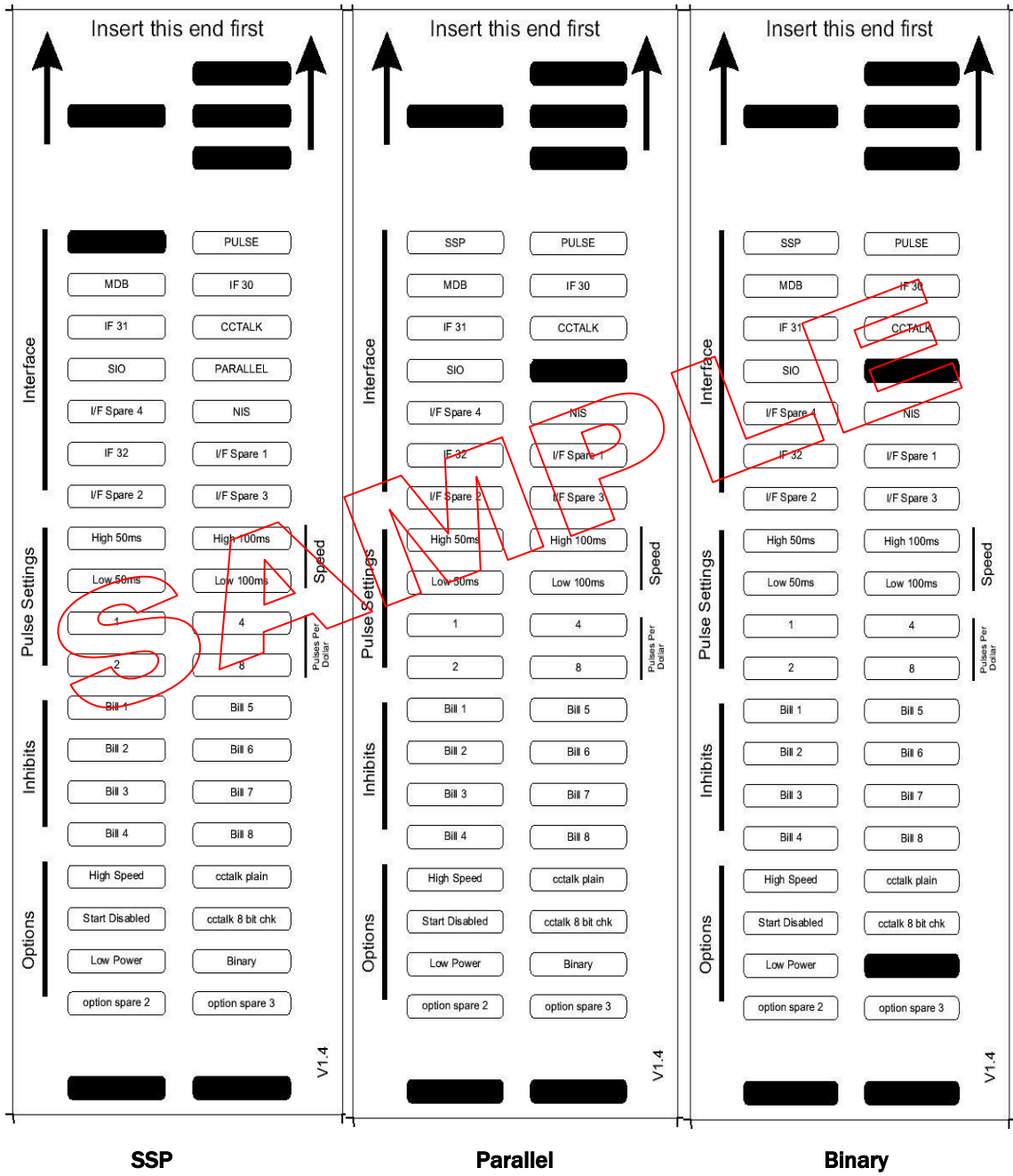

**Note:** These Configuration Cards are samples and should not be copied for programming use. Please see document GA713 for useable cards.

Insert this end first

Interface

SSP	PULSE
MDB	IF 30
IF 31	[REDACTED]
SIO	PARALLEL
I/F Spare 4	NIS
IF 32	I/F Spare 1
I/F Spare 2	I/F Spare 3

Speed

Pulse Settings

High 50ms	High 100ms
Low 50ms	Low 100ms
1	4
2	8

Pulses Per Dollar

Inhibits

Bit 1	Bit 5
Bit 2	Bit 6
Bit 3	Bit 7
Bit 4	Bit 8

Options

High Speed	cctalk plain
Start Disabled	cctalk 8 bit chk
Low Power	Binary
option spare 2	option spare 3

V1.4

**Encrypted ccTalk**

Insert this end first

Interface

SSP	PULSE
MDB	IF 30
IF 31	[REDACTED]
SIO	PARALLEL
I/F Spare 4	NIS
IF 32	I/F Spare 1
I/F Spare 2	I/F Spare 3

Speed

Pulse Settings

High 50ms	High 100ms
Low 50ms	Low 100ms
1	4
2	8

Pulses Per Dollar

Inhibits

Bit 1	Bit 5
Bit 2	Bit 6
Bit 3	Bit 7
Bit 4	Bit 8

Options

High Speed	[REDACTED]
Start Disabled	cctalk 8 bit chk
Low Power	Binary
option spare 2	option spare 3

V1.4

**Unencrypted ccTalk with  
16-bit Checksum**

Insert this end first

Interface

SSP	[REDACTED]
MDB	IF 30
IF 31	CCTALK
SIO	PARALLEL
I/F Spare 4	NIS
IF 32	I/F Spare 1
I/F Spare 2	I/F Spare 3

Speed

Pulse Settings

[REDACTED]	High 100ms
Low 50ms	[REDACTED]
1	[REDACTED]
2	8

Pulses Per Dollar

Inhibits

Bit 1	Bit 5
Bit 2	Bit 6
Bit 3	Bit 7
Bit 4	Bit 8

Options

High Speed	cctalk plain
Start Disabled	cctalk 8 bit chk
Low Power	Binary
option spare 2	option spare 3

V1.4

**Pulse – Pulse width  
50/100 mS  
4 Pulses per Dollar**



# BV100 Operations Manual

**Note:** These Configuration Cards are samples and should not be copied for programming use. Please see document GA713 for useable cards.

Insert this end first

V1.4

**SIO 300-Baud**

Insert this end first

V1.4

**SIO 300-Baud Starts Disabled**

Insert this end first

V1.4

**SIO 9600-Baud**

Insert this end first

V1.4

**SIO 9600-Baud Starts Disabled**

## 9.5 APPENDIX E – ESCROW CONTROL

The BV100 has a single note escrow facility (pin 10) used in Parallel and Binary modes. This allows the Validator to hold onto the note once accepted, and then only stack the note in the cash box when the host machine confirms that the Vend operation has been completed. If no confirmation of the Vend is received then the note will be returned to the customer after 30 seconds, (see Figure 11).

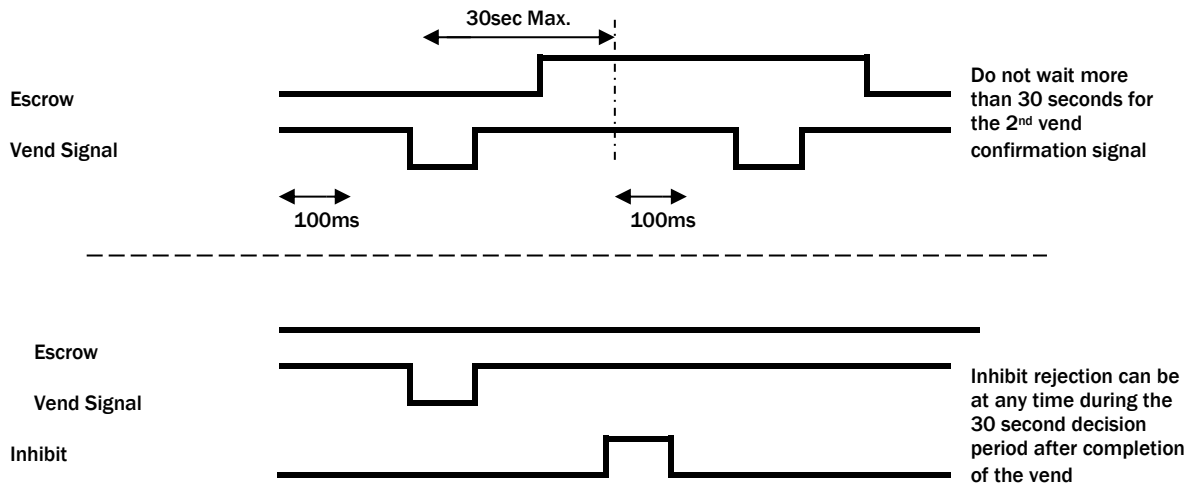

**Figure 11 - Escrow Timing Diagram for Parallel Vends**

If the host machine itself aborts the transaction by setting the corresponding inhibit input high, the note is returned immediately. The sequence of operations is as follows:

- Pin 10 held low awaiting note insertion.
- Note inserted. Validator issues a 100 ms pulse on the appropriate channel.
- The host machine initiates vend process.
- The host machine sets pin 10 high to indicate that it wants the note. If this is not done within 30 seconds the Validator will return the note.
- The Validator issues a 100 ms pulse on the appropriate channel after pin 10 going high to indicate final acceptance of the note. If the signal has not been received within 30 seconds it indicates the customer has forcibly retrieved the note and the vend will be aborted.
- The vend process is completed.
- The host machine sets pin 10 low in expectation of the next vend.

The host machine can force the return of the note to the customer by setting the inhibit line high, at any time before the end of the 30 second time-out. For channels above 4, setting all the inhibits high will cause a note reject.

In the event of a note being forcibly removed from the mouth of the BV100 during the 30 second interval, the BV100 will go out of service for 45 seconds.

## 9.6 APPENDIX F – INTERFACE TOOLS DA1-DA2

The DA1/2 Kits are designed for the following:

- Connecting of ITL Note Validators to a PC for the upgrade and user option setting of Currency and Firmware files.
- Testing note acceptance of Note Validators independent of the host machine to confirm that the validator is working. The DA1 and DA2 Kits comprise the following components:

DA1	DA2
DA1 adapter board	DA2 adapter board
DA1 to NV7-NV10 and BV cable	USB type A to Type B cable
DA1 to NV4 cable	DA2 to NV7-10 and BV cable
Power cable	Power cable
ITL support CD-ROM	ITL support CD-ROM

Table 11 – DA1 and DA2

### Connecting a DA1 to a validator and PC

For the PC system specification and set up refer to chapter 3.

Connect the DA1 to the validator as shown below (see Figure 12), using the 16-way to 5-way connector. The supplied 3.5 mm jack plug and 2 banana plugs are used to supply power to the DA1 when using a variable Bench power supply (Connect the +12 volts to the red banana plug and GND (0 V) to the black plug). Alternatively a Portable DC Power Adapter supplying 12 V and 1.5 A minimum can be used.

Plug the 9-way D-type connector into the serial port of the PC and note of the number of the port, as this will be needed later for configuring the software. Once the connections have been made install the appropriate software for the validator you are using.

**NOTE:** The Validator must be in Programming mode when connected to a computer and then returned to the Original Settings when the download is complete.

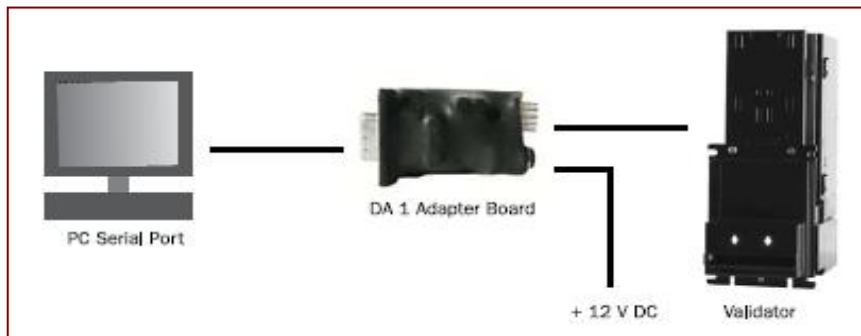
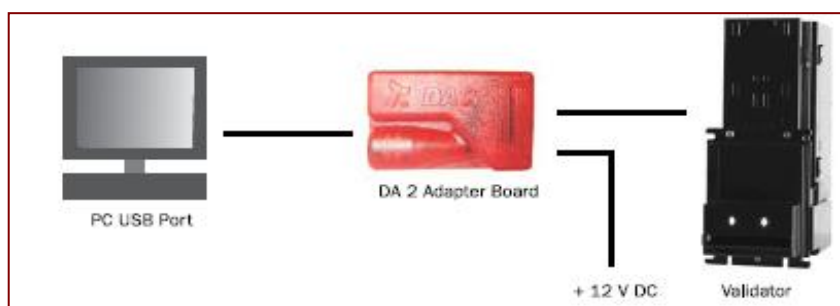

Figure 12 - Connecting DA1 to BV100 and PC for upgrading Validator programs

## Connecting a DA2 to a validator and PC



*Figure 13 - Connecting DA2 to a BV100 and PC for upgrading Validator Programs*

### Software Installation

DA1 - To install the ITL BNV Download Manager Software insert the CDROM into the correct PC drive. The CD should automatically run and an installation menu will appear. Double click the ITL BNV Download Manager and follow the on-screen instructions. You can also install the Currency files, Firmware files and the Technical Manuals for each specific product as well as other generic documentation.

The Quick Start Guide for the DA1 is Document number GA151.

DA2 - To install the ITL BNV Download Manager Software insert the CDROM into the correct PC drive. The CD should automatically run and an installation menu will appear. Double click DA2 installation guide (GA338) and follow the instructions relating to your specific Operating System. **Note:** All files contained on the CD are available from the ITL Website: [www.innovative-technology.co.uk](http://www.innovative-technology.co.uk)  
Please contact [support@innovative-technology.co.uk](mailto:support@innovative-technology.co.uk), if you require further assistance.

## 9.7 APPENDIX G – EXPLODED DIAGRAMS

Exploded Diagram Parts List:

Part No	Description	Qty	Drawing number
FD108	Note drive belt	2	GA706
LB152	BV note grip pad	2	GA705
MC226	Stacker drive shaft	1	GA707
MC230	BV Security tooth	1	GA711
MC235	Brass helical 12t 0.5m	1	only available as part of assembly
MC237	BV stacker thrust washer	1	GA710
MC255	Gearbox shaft	3	only available as part of assembly
MC258	Wheel axle	2	GA706
PM700	Main frame	1	GA706; GA707
PM701	Unit cable side (narrow)	1	GA705
PM761	Unit cable side (wide)	1	GA705
PM702	Unit side (narrow)	1	GA705
PM762	Unit side (wide)	1	GA705
PM704	Motor frame - stacker	1	GA710
PM705	Module case	1	GA708
PM706	Module path	1	GA708
PM707	Module cover plate	1	GA708
PM708	Front cover plate	1	GA705
PM709	Lightguide	2	GA706; GA708
PM710	Lightguide shield	2	GA706; GA708
PM711	Calibration strip	2	GA706; GA708
PM712	Bill push plate	1	GA705
PM713	Outer lift arm	1	GA707
PM714	Inner lift arm	1	GA707
PM715	Worm wheel - stacker drive	1	GA707
PM716	Crank arm gear	1	GA707
PM717	Crank arm - extended	1	GA707
PM718	Crank arm - recess	1	GA707
PM719	Belt drive wheel	2	GA706
PM720	Belt drive wheel flange	2	GA706
PM721	Flanged roller wheel	6	GA706
PM722	Roller bush	2	GA706
PM723	Roller wheel – clip in	2	GA706
PM724	Pressure wheel	10	GA708

Part No	Description	Qty	Drawing number
PM726	Stacker worm 0.7m	1	GA710
PM727	Stacker drive bush	1	GA710
PM728	Stacker drive collar	1	only available as part of assembly
PM732	Belt tension pulley	2	GA706
PM733	Cash box latch	1	GA705
PM734	Cash box body	1	only available as part of assembly
PM738	Lightpipe - push plate down	1	GA706
PM739	Bezel	1	GA705
PM740	Bezel lightguide	1	GA705
PM742	Cashbox lid	1	only available as part of assembly
PM745	Start sensor upper lightpipe	1	GA708
PM746	Start sensor lower lightpipe	1	GA706
PM747	Cashbox position lightpipe	1	GA708
PM751	Rear pressure wheel	2	GA705
PM763	Gearbox base plate	1	only available as part of assembly
PM764	Gearbox top plate	1	only available as part of assembly
PM765	Compound gear 1	1	only available as part of assembly
PM766	Compound gear 2	2	only available as part of assembly
PM767	Drive shaft	1	only available as part of assembly
OP111	Yellow filter	2	GA706; GA708
SC113	No4x6mm flange head pozi	3	GA708
SC119	M3x10 torx plastite pan head	2	GA706
SC123	M2.6x4 motor screws	2	GA710
SC124	4x12 torx pan BZP	9	GA705; GA708
SC126	M2x6 motor screw	2	GA709
SP124	Board support and cashbox latch	3	GA705
SP141	Ball bearing spring	2	GA705
SP142	3x20.5lg closed coil spring shaft	4	GA708
SP143	3x27.5lg closed coil spring shaft	6	GA708
SP144	Belt tensioner spring	2	GA706
SP146	BV cashbox door spring	2	only available as part of assembly
CN279	Cable Assy	1	GA708
MR108	Stacker motor	1	only available as part of assembly
MR111	Belt drive motor	1	only available as part of assembly

Table 12 - Parts list

1. FIT PADS LB152 TO PUSH PLATE PM712  
FIT BALL BEARINGS AND SPRINGS TO PM701/2
  - FIT SPRINGS TO FRONT COVER PM708
  - FIT LIGHTGUIDE PM740 TO BEZEL PM739
  - FIT SPRING TO LATCH PM733
  2. FIT CABLE - SEE INSTRUCTIONS BELOW
  3. FIT SIDES PM701/PM702
  4. FIT FRONT COVER PM708
  5. FIT BEZEL PM739
  6. FIT LATCH PM733/SP127
  - (7. FIT CABLE TO MODULE IF REQUIRED)
- 
- A. PASS THE CABLE THROUGH THE SIDE PM701
  - B. PASS THE CABLE UNDER THE BELT ANT LOCATE  
IN THE SLOT IN MAIN BODY PM700
  - C. FEED THE CABLE ROUND THE MOTOR  
AND PLUG INTO PCB
  - D. PLUG IN CONNECTORS TO MOTOR PCB:  
YELLOW/WHITE TO BELT DRIVE MOTOR  
RED/BROWN TO STACKER MOTOR

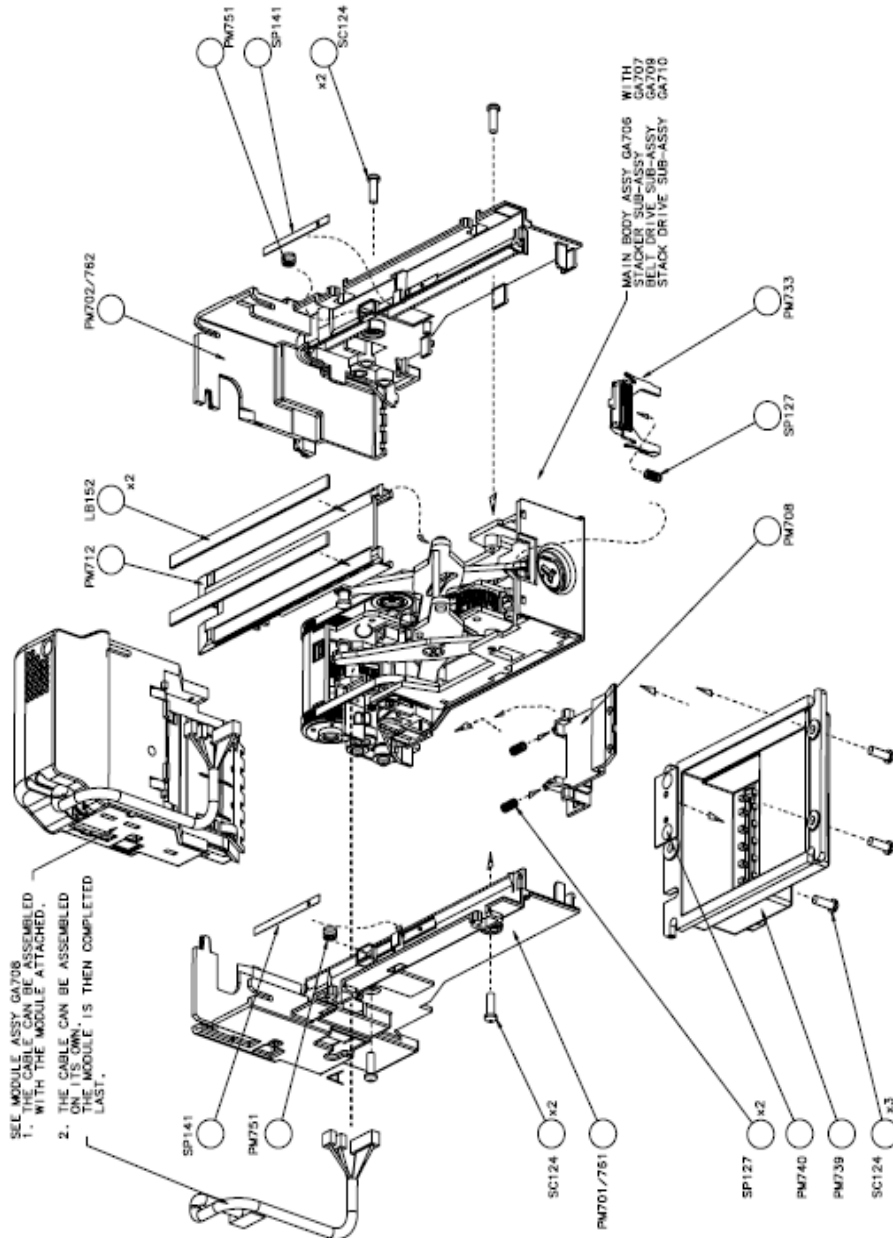

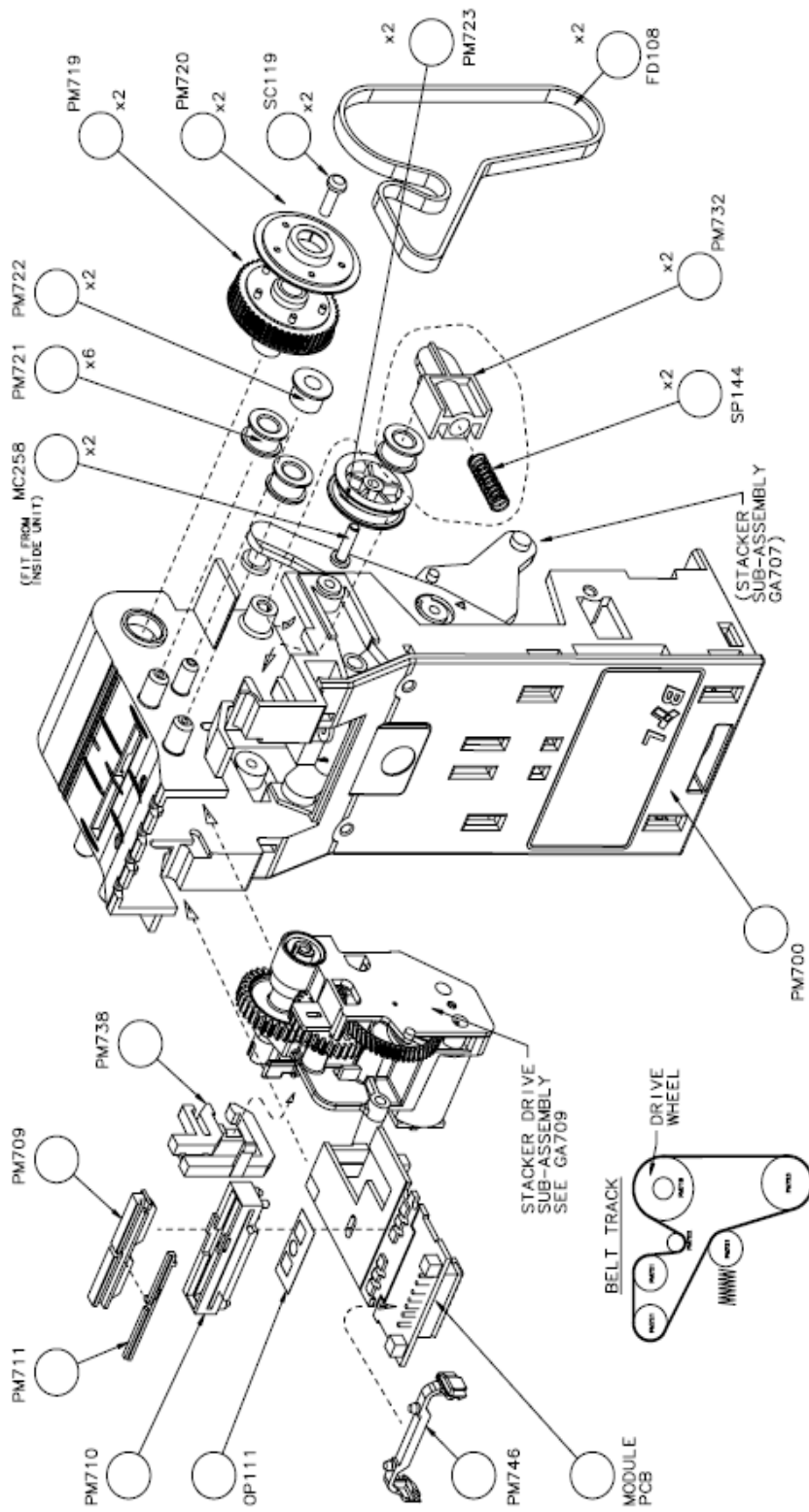

1. ASSEMBLE PCB PARTS, FIT INTO PM700
2. PRESS PM719/720 TOGETHER AND HEAT STAKE 5 PIPS
3. FIT LIGHTGUIDE TO MOTOR SUB - ASSY
4. SLIDE IN MOTOR SUB - ASSY (GA709)
5. FIT DRIVE WHEELS AND FIX WITH SCREWS SC119
6. FIT WHEELS AND BELTS ON BOTH SIDES

SAME COMPONENTS ON OPPOSITE SIDE  
 NUMBER OF COMPONENTS IS FOR BOTH SIDES



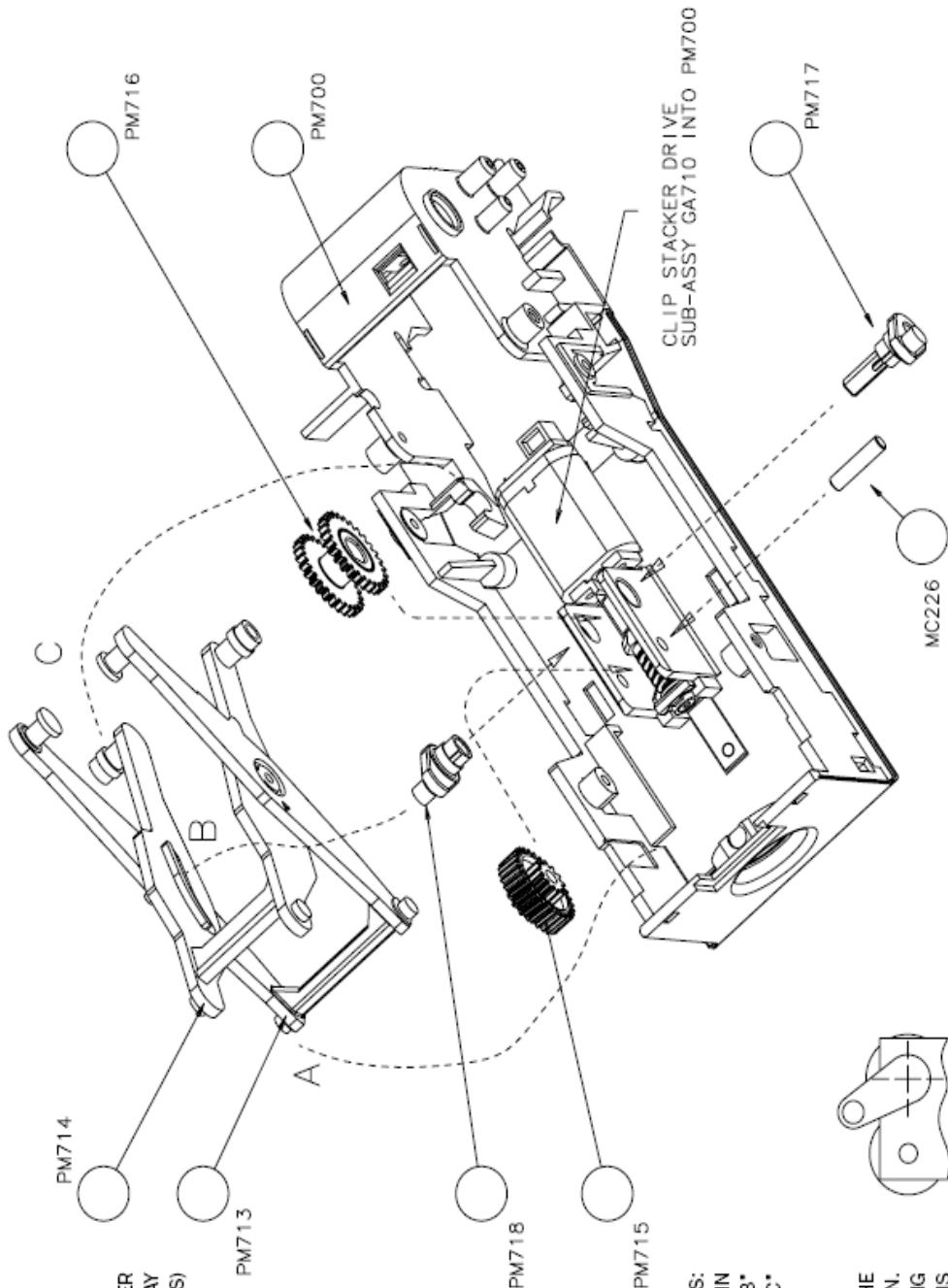

FIT SCISSOR ARMS TOGETHER  
(THEY ONLY FIT ONE WAY  
LINE UP THE TRIANGLES)

ONE WAY TO ASSEMBLE ARMS:  
LOCATE "C" BUT DO NOT CLIP IN  
DEFORM ARMS TO CLIP IN "B"  
LOCATE "A" IN SLOT CLIP IN "C"

ALIGN CRANK ARMS AT ABOUT THE  
POSITION SHOWN.  
IT HELPS WHEN FITTING  
THE SCISSOR ARMS

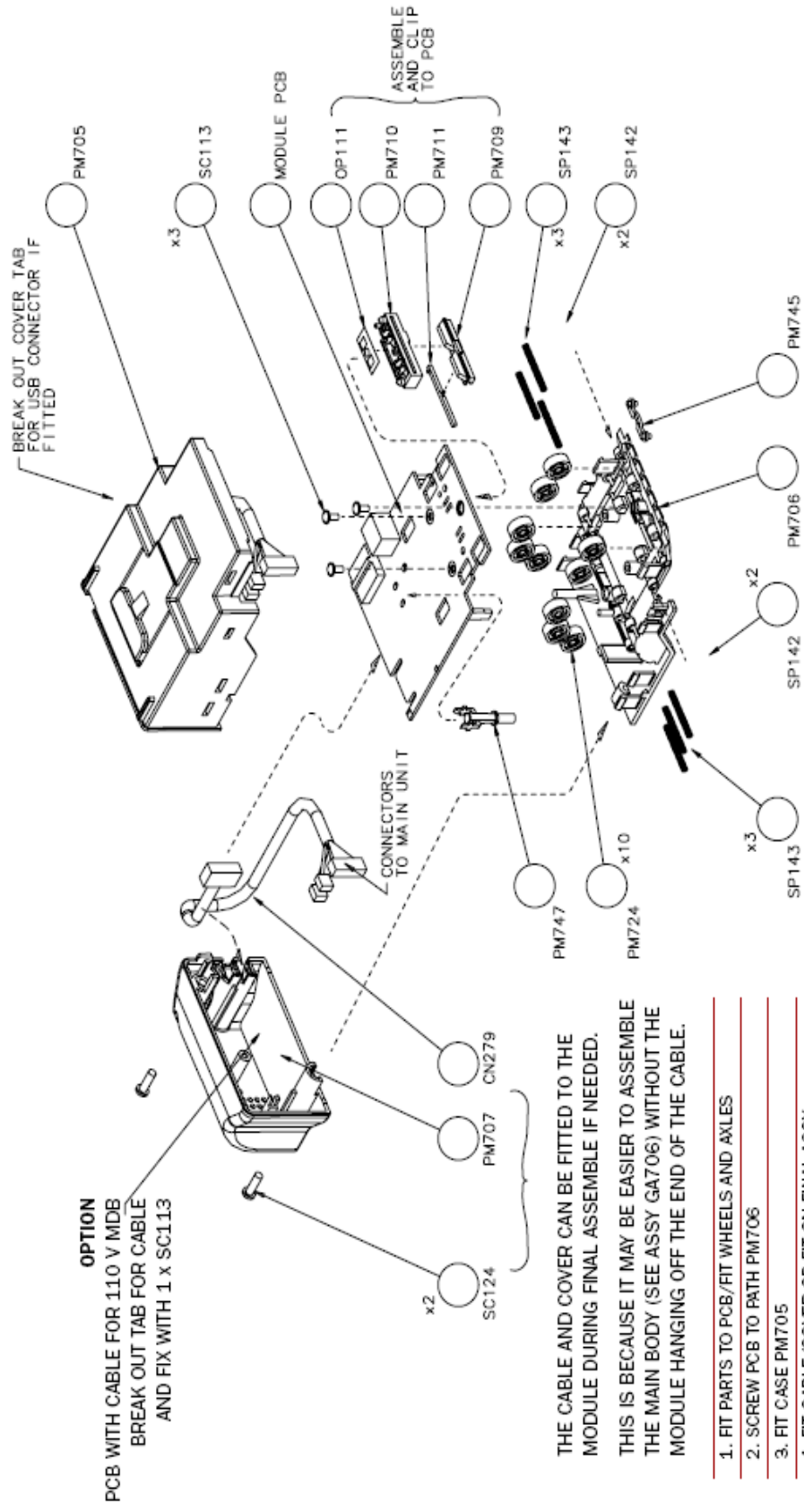

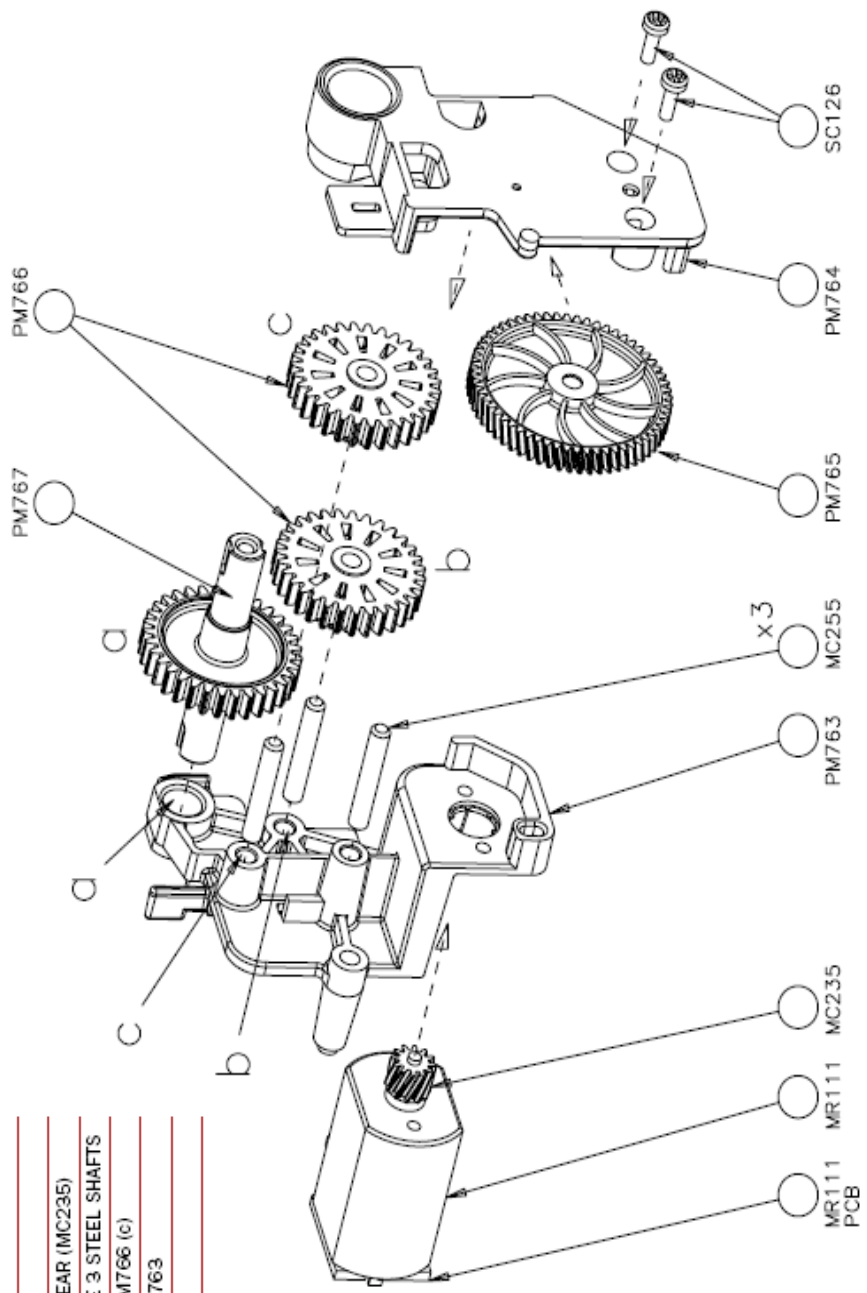

1. PRESS FIT 3 SHAFTS (MC255) INTO PM763
2. ASSEMBLE MOTOR (MR111) WITH PCB AND GEAR (MC235)
3. SPREAD A SMALL AMOUNT OF GREASE ON THE 3 STEEL SHAFTS
4. FIT GEARS IN ORDER: PM767 (a) PM766 (b) PM766 (c)
5. SLIDE PM765 INTO PM764, FIT PM764 TO PM763
6. FIT MOTOR AND FIX WITH 2 off SC126

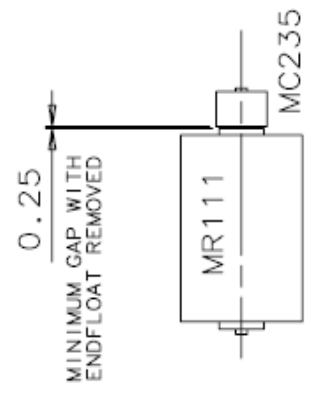

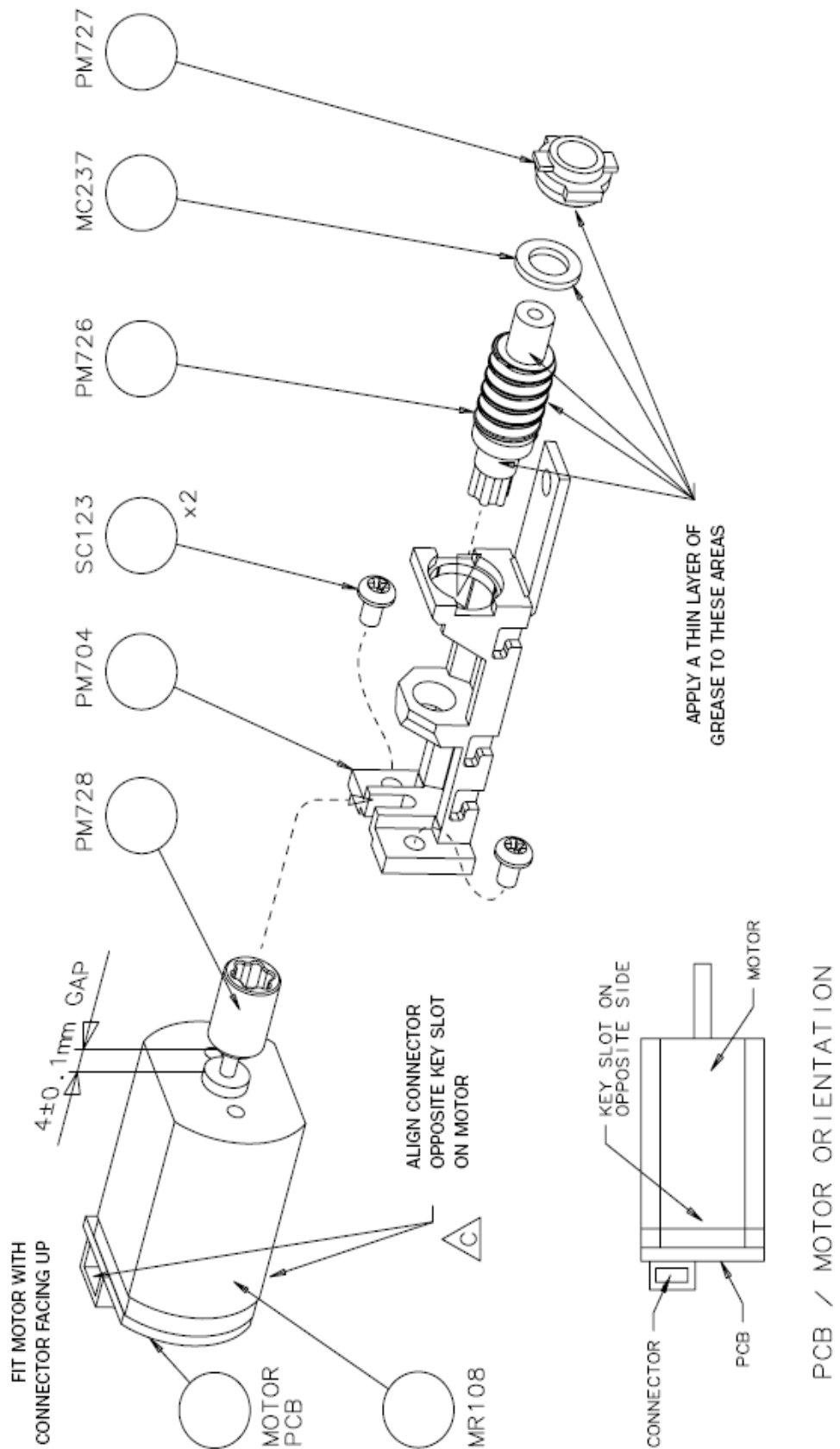

## 10 INDEX

### INDEX OF TABLES

<b>Table 1</b>	<b>Environmental requirements</b>	<b>5</b>
<b>Table 2</b>	<b>Power requirements</b>	<b>5</b>
<b>Table 3</b>	<b>Interface logic levels</b>	<b>5</b>
<b>Table 4</b>	<b>Available interfaces/protocols</b>	<b>6</b>
<b>Table 5</b>	<b>Bezel LED status codes</b>	<b>8</b>
<b>Table 6</b>	<b>16 pin connector details</b>	<b>9</b>
<b>Table 7</b>	<b>Configuration button functions</b>	<b>10</b>
<b>Table 8</b>	<b>Receive and transmit codes</b>	<b>14</b>
<b>Table 9</b>	<b>Example protocols</b>	<b>15</b>
<b>Table 10</b>	<b>Electrical requirements and characteristics for low power</b>	<b>19</b>
<b>Table 11</b>	<b>DA1 &amp; DA2</b>	<b>36</b>
<b>Table 12</b>	<b>Parts list</b>	<b>39</b>

### INDEX OF FIGURES

Figure 1	The BV100 validator	6
Figure 2	Interface connector	8
Figure 3	Open head latch	9
Figure 4	Cash box release button and access door	9
Figure 5	Pin detail	9
Figure 6	ccTalk Connection pins on the BV100	12
Figure 7	MDB Opto Isolated Input / Output circuit BV100 MDB slave	12
Figure 8	Typical Serial Output: Transmission of the value 20 (decimal), Note not recognized	13
Figure 9	Typical Serial Output: Transmission of the value 20 (decimal), Note not recognized	13
Figure 10	Low Power Mode Timing Diagram	20
Figure 11	Escrow Timing Diagram for Parallel Vends	35
Figure 12	Connecting DA1 to a BV100 and PC for upgrading Validator Programs	36
Figure 13	Connecting DA2 to a BV100 and PC for upgrading Validator Programs	37

	<b>PAGE</b>
bezel	5, 6, 8, 10, 16, 18, 22, 23, 25, 28, 29, 39
box	6, 8, 12, 22, 25, 35, 39
button	8, 10, 11, 17, 18, 19, 22, 28, 29
cash	6, 8, 11, 18, 22, 25, 27, 35, 39
ccTalk	6, 10, 12, 18, 25, 28, 29
communication	8, 12, 17, 18, 19
connector	8, 9, 12, 36
consumption	7, 19, 26
credit hold function	17, 29
escrow	9, 14, 15, 16, 17, 35
humidity	5
interface	5, 6, 8, 9, 11, 12, 13, 15, 16, 17, 18, 22, 23, 25, 28, 29, 36
multi-drop bus	11, 12
pin	3, 8, 9, 12, 15, 16, 17, 18, 20, 35
protocol	6, 7, 9, 10, 11, 12, 13, 15, 18, 19
Smiley Secure Protocol	11, 13
status	8, 10, 12, 14, 15, 22
supply	5, 7, 8, 9, 19, 22, 26, 36
temperature	5
voltage	5, 7, 19, 22, 26
Windows	7

## REVISION HISTORY

INNOVATIVE TECHNOLOGY LTD			
TITLE	BV100 OPERATIONS MANUAL		
DRAWING NO	AUTHOR	DATE	FORMAT
GA717	RJS	10/10/07	MS Word 2000

ISSUE	RELEASE DATE	MODIFIED BY	COMMENTS
A	10/10/07	RJS	First Draft
1	04/12/07	RJS	First Release
2	08/12/08	DP	Updated IF30 information
3	06/01/09	RJS	General update
4	13/08/14	MH	General Update